



HIGH LEVEL ACCESS SOLUTIONS



FALL ARREST SYSTEM HWS-FAS 8

IN WIND TURBINE GENERATORS AND MACHINE INSTALLATIONS
EN 353-1:2014

Translation of assembly and operating instructions

English
Art. no.
1122509

Revision and modification

04/2018 V01R00 EN

Hailo Wind Systems GmbH & Co. KG

Kalteiche-Ring 18

35708 Haiger, Germany

Phone: +49 (0) 2773 82-0

Fax: +49 (0) 2773/82-1561

E-mail: info@hailo-windsystems.com

Internet: www.hailo-windsystems.com

© Hailo Wind Systems – Without the prior written consent of Hailo Wind Systems, no part of this publication may be reproduced in any way, transmitted, transcribed, stored in a storage medium or translated into any language or computer language. Copyright infringement may also affect the product support by Hailo Wind Systems for this equipment. Hailo Wind Systems reserves the right to make changes to this manual and the product it describes without prior notice. The content of this manual does not include any contractual or other obligations by Hailo Wind Systems and is not legally binding. This publication was prepared with great care. However, should you find any errors or wish to make suggestions for improvement, please write to Hailo Wind Systems. The original language of this document is German. If required, you can request a copy in writing.

Contents

1.	Project information	4
2.	About this document	5
3.	EC declaration of conformity	7
4.	EC-type test approval certificate	8
5.	Standards and regulations	9
6.	Safety	10
	6.1 Intended use	10
	6.2 Safety instructions	12
	6.3 Protective equipment	17
7.	Transport and storage – Technical data	20
8.	System overview	21
9.	Technical specifications	22
10.	Assembly	24
11.	Usage	32
	11.1 Fall arrester HWS SKC EVO	32
	11.2 Ascent and descent	38
	11.3 Rescue measures	40
12.	Inspection and maintenance	42
13.	Assembly log	44
14.	Log for inspection	46

1. Project information

Information from the manufacturer

Order number	
Year of manufacture	
Manufacturer	Hailo Wind Systems Kalteiche-Ring 18 35708 Haiger, Germany

Location (to be completed by the operator)

Name (operator)	
Address	
Contact	
Date of commissioning	
Signature of operator	

System data (to be completed by the assembly manager)

Climbing equipment	Ladder system (Hailo Wind Systems)	<input type="checkbox"/>
	Ladder system (on site)	<input type="checkbox"/>
	Crampon corridor (on site)	<input type="checkbox"/>
Ladder construction	Aluminium	<input type="checkbox"/>
	Stainless steel	<input type="checkbox"/>
	Galvanised steel	<input type="checkbox"/>
	Other	<input type="checkbox"/>
Cable version	ES 8 (stainless steel)	<input type="checkbox"/>
	ZS 8 (galvanised steel)	<input type="checkbox"/>
Marking (see wire rope thimble swaging cable)	Batch no. / code no.:	
Date/signature Assembly manager		

2. About this document

These assembly and operating instructions describe the installation, use and maintenance and testing of the HWS-FAS 8 fall arrest system.

Please read these instructions completely and follow all safety instructions before starting the assembly work and using the system. In the event of damage resulting from non-observance of these instructions and the safety information, Hailo Wind Systems shall assume no liability.

These assembly and operating instructions are only valid for the HWS-FAS 8 fall arrest system of Hailo Wind Systems.



NOTICE **Product changes**

The right to make technical modifications and improvements which do not apply to the tested prototype in regard to safety-relevant criteria is reserved by Hailo Wind Systems.

The right to make changes to the content of the technical documentation is reserved by Hailo Wind Systems.



Language of the manual

If the system is resold to a buyer in another country, it is necessary for the safety of the user that this manual be made available in the respective national language. Translations can be requested from documentation@hailo-windsystems.com.



Designation

In this booklet and all related documents, the term “guided fall arrester including fixed guide” as used in EN 353-1: 2014 will be replaced by “fall arrest system” for better user understanding.

2. About this document

Classification of the safety instructions

This manual contains four classes of safety instructions with highlighting of useful and important information (tips/info).

A distinction is made between:



DANGER!

DANGER indicates an imminently threatening dangerous situation which could lead to serious injuries or death if not avoided.



WARNING!

WARNING indicates a possible dangerous situation which could lead to serious injuries or death if not avoided.



CAUTION!

CAUTION indicates a possible dangerous situation which could lead to minor injuries if not avoided.



NOTICE

NOTICE indicates a possible dangerous situation which could lead to property damage if not avoided.



Tip / information

This symbol is used to draw your attention to important or helpful information.

3. EC declaration of conformity



The manufacturer or his authorised representative established within the company:

Hailo Wind Systems GmbH & Co. KG
Kalteiche-Ring 18
35708 Haiger, Germany

hereby declares that the HWS-FAS 8 system described in the following pages complies with the provisions of Directive 89/686/EEC and the standard EN 353-1:2014 (for the PPE in accordance with Article 8 (3) of the Directive) and is identical to the PPE which was the object of the

Dekra EXAM,

Dinnendahlstrasse 9, D-44809 Bochum, identification no. 0158,

for which **EC-type test approval certificate no. ZP/B007/18** was issued and which is subject to the procedure laid down in Article 11 (A) of Directive 89/686/EEC, under the control of the notified body

Dekra EXAM,

Dinnendahlstrasse 9, D-44809 Bochum, identification no. 0158.

Haiger, 06/03/2018

Place, date

Signature of the authorised person (J. Weg)

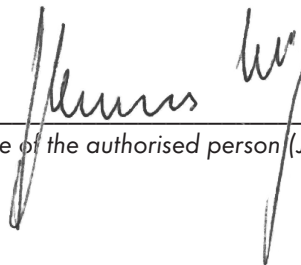

4. EC-type test approval certificate

TRANSLATION

(1) EC-Type Examination Certificate

- (2) Council Directive of 21 December 1989 on the approximation of the laws of the member states relating to personal protective equipment - 89/686/EEC
- (3) No. of EC-Type Examination Certificate: **ZP/B007/18**
- (4) Product: **Guided type fall arrester including a rigid anchor line
Guided type fall arrester, type: HWS SKC EVO
Rigid anchor line, type: HWS-FAS 8**
- (5) Manufacturer: **Hailo Wind Systems GmbH & Co. KG**
- (6) Address: **Kalteiche-Ring 18, 35708 Haiger, Germany**
- (7) The design and construction of this personal protective equipment and any acceptable variation thereto are specified in the schedule to this type examination certificate.
- (8) The certification body of DEKRA EXAM GmbH, Notified Body No. 0158 according to Article 9 of Council Directive 89/686/EEC of 21 December 1989, certifies that this personal protective equipment has been found to comply with the Essential Health and Safety Requirements given in Annex II to the Directive. The examination and test results are recorded in the test and assessment report **PB 18-012**.
- (9) The Essential Health and Safety Requirements are assured by compliance with
DIN EN 353-1:2014
- (10) This EC-Type Examination Certificate relates only to the design, examination and tests of the specified personal protective equipment in accordance to Directive 89/686/EEC. Further requirements of the Directive apply to the manufacturing process and supply of this personal protective equipment. These are not covered by this certificate.
- (11) When applying the CE Marking to the products that conform to the types examined, the client is obliged to add, in accordance with the attached pattern, the identification number of the Notified Body **CE 0158** engaged in production control.
- (12) This EC-Type Examination certificate is valid until 2023-03-05.

DEKRA EXAM GmbH
Bochum, 2018-03-06

signed: Wiegand
Certification body

signed: Mühlenbruch
Special services unit

We confirm the correctness of the translation from the German original.
In the case of arbitration only the German wording shall be valid and binding.

Certification body

Special services unit



Page 1 of 4 of ZP/B007/18
This certificate may only be published in its entirety and without any change.

DEKRA EXAM GmbH, Dinnendahlstrasse 9, 44809 Bochum, Germany
telephone +49.234.3696-105, fax +49.234.3696-110, zs-exam@dekra.com

5. Standards and regulations

- **EN 353-1:2014:** Personal fall protection equipment: Guided fall arresters including fixed guide
- **EN 361:** Personal fall protection equipment: Arrest harnesses
- **EN ISO 14122:** Safety of machinery – fixed access to mechanical equipment
- **EN 13101:** Crampons in shafts
- **EN 14396:** Stationary ladders for shafts
- **EN 50308/B-1:** Wind turbines – work safety
- **DIN 18799-1:** Ladders on structural installations
- **DIN CEN/TS 16415:** Attachment devices
- **89/686/EWG:** European guideline for personal fall protection equipment
- **89/656/EWG:** Minimum safety and health requirement when using personal protective equipment for workers at work
- **EN 795:** Personal fall protection equipment – attachment device
- **German ordinance BetrSichV:** Regulation on safety and health in the use of work equipment
- **DGUV Regulation 1:** Accident prevention regulations “Principles of Prevention”
- **DGUV Rule 208-016:** Operation instructions for handling ladders and steps
- **DGUV Rule 112-198:** Rules for the use of personal protective equipment for fall prevention
- **DGUV Rule 112-199:** Rules for the use of personal protective equipment for rescues from heights and depths

6. Safety

6.1 Intended use

The fall arrest system is designed as fall protection when using ladders and crampon corridors both above and below ground. It is used to ensure safe ascent and descent of service personnel to high or low-lying workplaces.

A fall arrester rope, which serves to guide the fall arrester HWS SKC EVO, is mounted on the access ladder attached in the structure in the middle of the access ladder or crampon corridor.

The user connects his/her personal fall protection equipment (PFPE) with the fall arrester, which runs along the entire length of the climbing equipment and is equipped with the energy absorber BFD140FAS8.

The fall arrest system HWS-FAS 8 may only be used with fall arrester HWS SKC EVO.

The operator must ensure that this information booklet is kept with every fall arrest system and is available to the user whenever needed.

The employer or operating company of an installation must provide a plan in which all possible emergencies that can occur when using the access ladder system are taken into account and the necessary rescue measures are explained.

The fall arrest system may only be used by persons who are instructed in the use of the access ladder and fall arrest system and who are familiar with the safety plan in the wind turbine generator or machine installation.

This includes any necessary rescue measures along with their initiation and implementation. The accident prevention regulations applicable to the respective installation site as well as the safety regulations listed here are to be followed.

These assembly and operating instructions must be observed by all persons who install and use the fall arrest system.

The precondition for safe handling as well as faultless assembly and use of the access ladder is compliance with the safety instructions and regulations. The fall arrest system may only be installed by trained persons.

The fall arrest system may only be used for its intended purpose.

Its misuse is prohibited and can lead to failure of the safeguarding system in the event of a fall.

The climbing equipment may not be used in the following cases:

- Improper assembly
- Safety defects or improperly performed repairs
- Unauthorised or unapproved modifications to the climbing equipment
- Use of any parts other than genuine spare parts
- Insufficiently qualified personnel
- Unfamiliarity with or non-observance of these assembly and operating instructions
- Inadequate maintenance and care or neglect of timely testing of the access ladder and fall arrest system.

No liability will be assumed for harm to persons or damage to equipment arising from violation of the provisions stipulated here or non-observance of the safety instructions.

6.2 Safety instructions



- Before installing and using the fall arrest system, the instructions must be carefully read and understood.
- Observe the safety regulations and notes in the information booklet for the fall arrester before you use the fall arrest system.



- Before using the ladder system, learn about the emergency plan and rescue measures that may be necessary.
- Comply with the safety regulations for wind turbine generators as well as the instructions issued by the manufacturer of the system.

Securing the user



WARNING! **Danger of falling!**

When working at heights, there is a risk of injury from falling.

For this reason, observe the following:

- Before using and installing the system, always secure yourself with the personal fall protection equipment (PFPE).
- Do not use the climbing equipment if you feel unwell or are in poor physical condition.

- Personnel requirements**
- The installation and use of the climbing device and the fall arrest system may only be carried out by instructed personnel.
For more information on service training, visit www.hailo-windsystems.com/sara.
 - There must always be two persons in the WTG when using the climbing equipment. The persons must be able to place an emergency call at any time.
 - The user of the fall arrest system must be physically and mentally able to walk on the particular installation.
 - The use of the climbing equipment after ingesting medications, alcoholic or psychotropic substances that may impair capabilities, balance or concentration is prohibited.
- Max. number of persons in the fall arrest system**
- A maximum of five people may be simultaneously secured in the climbing equipment with the fall arrest system. A minimum distance of 6 m must be maintained between each climbing person.
- Max. load capacity**
- Users of the fall arrest systems must have a minimum weight of 50 kg (without tools and equipment).
 - Users of the fall arrest system may not exceed a weight of 140 kg (including tools and equipment).

Ambient conditions

- Extreme temperature and weather conditions (e.g., heavy rain/snow, temperatures from $<-40\text{ }^{\circ}\text{C}$ or $>+50\text{ }^{\circ}\text{C}$) may impede the functionality of the fall arrest system. Use is prohibited when there is heavy icing or soiling of the fall arrest system.

Condition of the climbing equipment

- Before each use, a visual inspection of the fall arrest system and the fall arrester must be carried out. The system or components of the system are to be withdrawn from use immediately if there are doubts about their safe condition.
- Dirty or damaged equipment affects the functioning of the fall arrest system. Contact with oils, acids or other corrosive liquids should be avoided. In particular, the fall arrester rope must be clean and undamaged.
- Do not store any equipment or objects below the climbing equipment that would pose an additional hazard in the event of a fall. Make sure that no scaffolding, platforms or anything similar protrudes into the work area.

Test of climbing equipment and fall arrest system

- The prescribed intervals for recurring inspections/maintenance must be adhered to.
- The proper condition of the fall arrest system must be checked at least once a year by a competent and qualified person.
- In the event of a fall, the system must be checked immediately by a competent and qualified person and, if necessary, repaired or restored.

Assembly and repairs

- Damaged components may only be replaced with original parts by qualified personnel (authorised by the manufacturer). Any necessary repairs or retrofits must be carried out in accordance with the procedures and relevant standards specified by the manufacturer.
- No modification or extension of the fall arrest system may be made without the express prior written consent of the manufacturer.
- Never disable the safety equipment.

System combinations

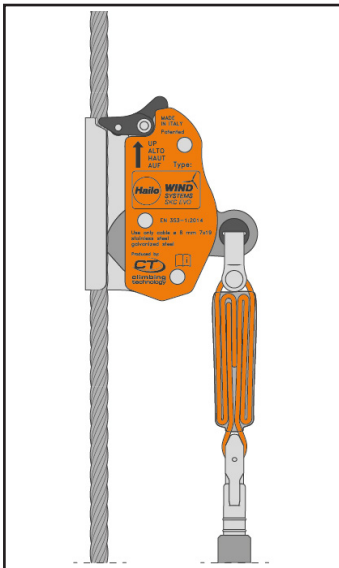

DANGER! Fall hazard due to unacceptable system combination.

The fall arrest system HWS-FAS 8 may only be used with the fall arrester **HWS SKC EVO**.

The number of required fall arresters depends on the number of users of the climbing system.

- The combination with components from other manufacturers can lead to failure of the entire system and of the security system in the event of a fall.
- If the use of components from other manufacturers is unavoidable, the written approval of Hailo Wind Systems is required.
- A combination of pieces of equipment (i.e., connection of user-specific safety harnesses to the fall arrester) should not impair the overall system. Always follow the enclosed instructions.

Use of climb assist systems

- The use of climb assist systems (motorised or with a counterweight) may impair the safety function of the fall arrest system. The operator who combines these two systems must first perform a functional test with subsequent issue of a declaration of clearance and have it certified by a notified testing laboratory. The unrestricted safety and function of the HWS-FAS 8 fall arrester system in conjunction with the respective climb assist system must be guaranteed and documented.

6.3 Protective equipment



Put on personal fall protection equipment (PFPE)

Protection against falls from above a minimum height. The personal fall protection equipment must be properly selected, used and checked.



Carry a communication device (mobile phone, radio unit)

When in or on the wind turbine generator, constant voice contact must be ensured between the involved persons.



Wear a helmet

Head protection for falling objects and impacts from falls or in confined spaces.



Wear safety footwear

Foot protection from heavy falling objects, slipping, or stepping on sharp-edged parts that are lying around.



Wear safety gloves

Protect hands from friction, abrasions, stabs and cuts.

Personal protective equipment

- Check personal fall protection equipment (PFPE) **every working day** to ensure that it is in perfect and safe condition. The safety of the user depends on the effectiveness of their equipment.
- Personal protective equipment, as well as the fall arrester HWS SKC EVO, should be in the personal possession of the respective user and only be used by them. Use by an extended group of individuals is not appropriate.

6. Safety

Adjusting the safety harness

- Only use safety harnesses according to EN 361 and observe the corresponding operating instructions.
- Do not use tether straps, seat belts or older harnesses that only partially encircle the body. These straps should not be used when climbing.
- The harness must be firmly attached to the body and adjusted correctly.
- A loose safety harness that is not set tightly enough is a safety hazard and not permitted during use.

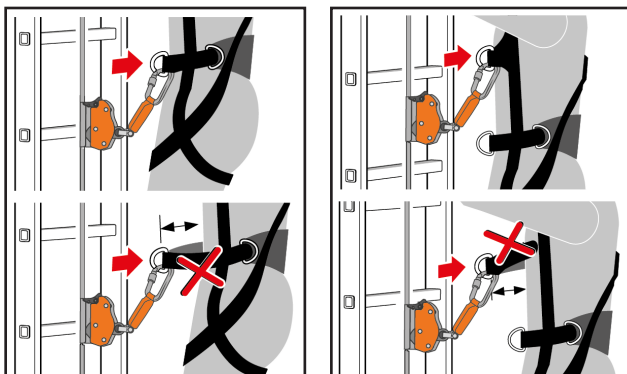

Additional means of connection

- The shortest possible connection lengths of the additional safety systems should be chosen so that the fall distance is effectively limited in the event of a fall.
- Additional means of connection, e.g., Y-connectors, may only be attached to the attachment points (EN 795) provided for this purpose.

Connecting with the belt



WARNING!

Fall hazard if used incorrectly.

- The snap hook of the energy absorber may only be latched to an approved fall arrest ring of the safety harness.
- The fall arrester HWS SKC EVO must not be connected to the fall arrest rings of the safety harness, which may be present in the hip area as an additional element.
- Connecting elements on the fall arrester may not be lengthened or shortened.

7. Transport and storage – Technical data

Transport and storage

- All parts of the system must be secured so that no impairment of their function occurs and all components are perfectly safe.
- Before mounting the fall arrest system, all parts must be checked for fault-free condition. There can be no transport damage to system components. Damaged parts are to be replaced prior to assembly.

Technical data

- The fall arrest system is designed for operation in a temperature range of -40 °C to + 50 °C.
- The fall arrester rope may have a deviation from the vertical of up to $\pm 15^\circ$ for safe use of the fall arrester.

Nameplates of the fall arrest system

- Do not remove any markings and regularly check their legibility.
- The operator of the system must attach to the structure a warning that will unequivocally inform the user about the 3 m safety distance.

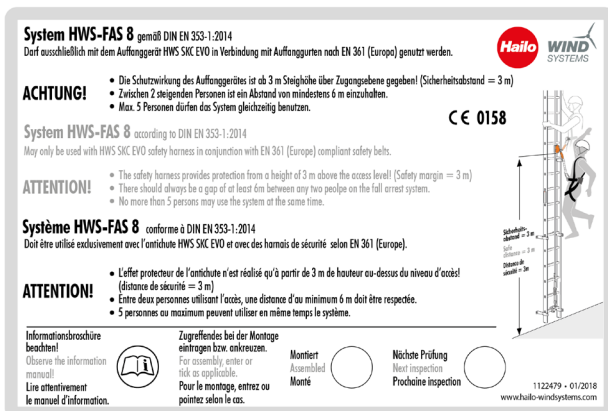

8. System overview

Rope guide centred on ladder rung

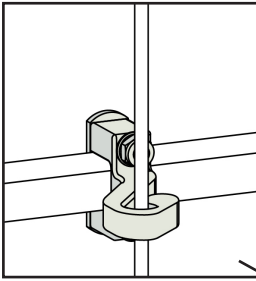

Rope suspension at the top centred on ladder rung

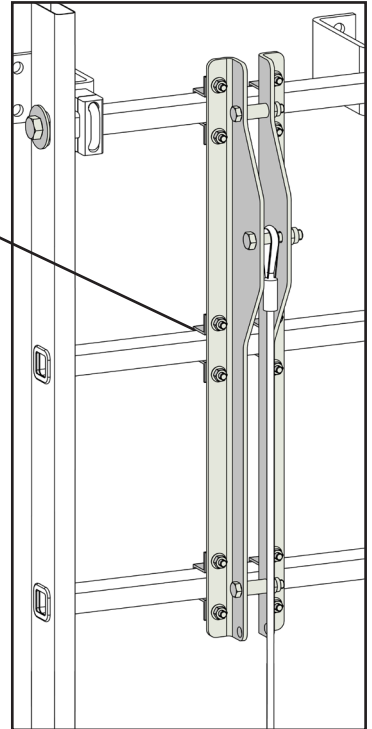

Rope suspension at the bottom

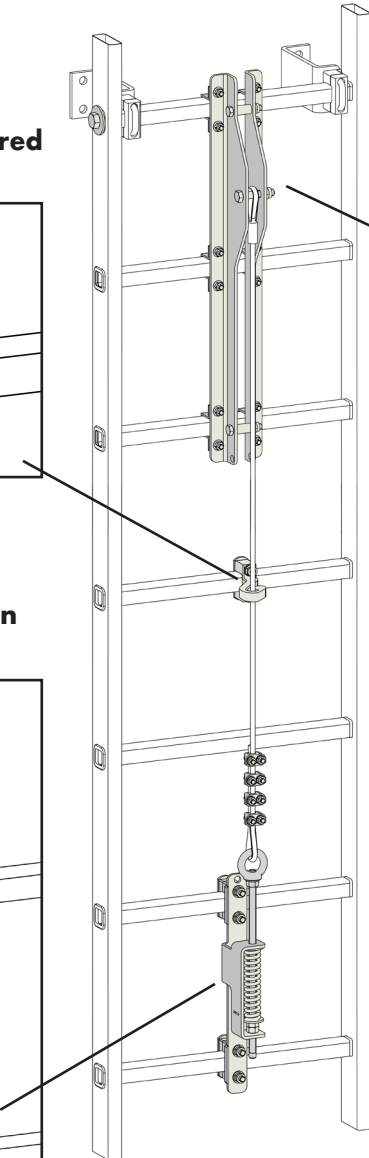
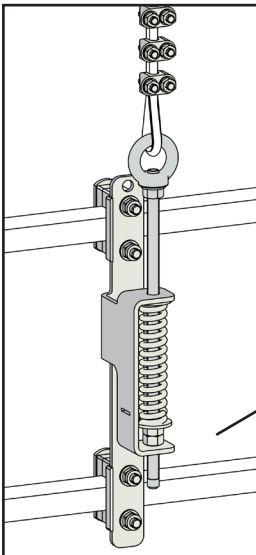

9. Technical specifications

Proof of load-bearing capacity

- Prior to beginning assembly, it must be checked that the expected loads can be borne by the supporting structure. If no relevant information or documentation is available for this, a structural certification must be produced, which takes the required load-bearing capacity into account.
- Make sure that a 6 kN load and a 15 kN static load can be absorbed by the overall system in the event of a fall.
- If the necessary certifications are not on record documenting safe absorption of forces on the supporting structure, Hailo Wind Systems shall assume no liability for cases of damage.
- For concrete structures, only approved anchor fittings may be used. In the case of undefined subsurfaces, the fixing system must be implemented in consultation with the structural engineer. Requirement for concrete: A concrete grade of at least C 20/25 is required.

Specifications for retrofitting

- If the fall arrest system HWS-FAS 8 is retrofitted to existing climbing equipment (the standards EN ISO 14122-4, DIN 18799-1 or EN 14396), its safe use must be ensured. Factors to be considered include a smaller cross-section, unsustainable rails or rungs, corrosion or poor or insufficiently strong anchorage to the structure.
- Climbing protection systems are mandatory from a fall height ≥ 5 m (according to DIN 18799-1) or ≥ 3 m (according to EN ISO 14122-4).

Maximum installation angle

- Instructions for installing the fixed guide, including max. installation angle of $+15^\circ / -15^\circ$ to the vertical are to be observed.

9. Technical specifications

Positioning of the first ladder holder

- When using the cable-guided fall arrest system, the following guidelines must be observed when positioning the first ladder holder pair:
- The fit of the first ladder holder pair depends on the type of ladder fastenings

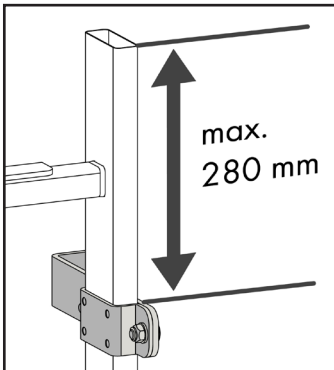

Ladder fastening with rail clamps

- The last ladder holder may lie no more than 280 mm under the end of the rail.

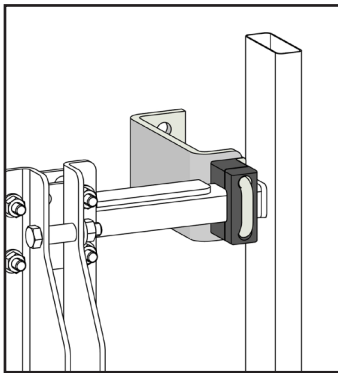

Ladder fastening with rail clamps

- The last ladder holder is attached to the first rung from the top.

Positioning of the attachment points

- Attachment points within the climbing system are to be chosen in such a way as to minimise free fall and fall height.
- The attachment point must be in the operating radius of the user who is still secure.

Rope requirements

- For fixed guidance, only a \varnothing 8 mm 7x19 rope made of stainless steel or galvanised steel from Hailo Wind Systems may be used.

Safety of assembly personnel



DANGER! **Danger of falling!**

When working at heights, there is a risk of injury from falling.

For this reason, observe the following:

- Especially observe the safety instructions in the "Safety" section.
- When installing, use an approved fall protection system and personal fall protection equipment (PFPE). Use an approved attachment point as specified in DIN EN 795 or CEN/TS 16415.
- The assembly personnel may not be secured to the system to be installed.
- At least two people are required to install the fall arrest system.

Assembly log

- The assembly of the fall arrest system must be fully documented by the assembly manager of the assembly company.
- You must fill out the assembly log **completely** in the last section of these instructions.
- Complete the project details in the first section of this manual **in full**.
- Example of a tightening torque specification:

Specification of tightening torques

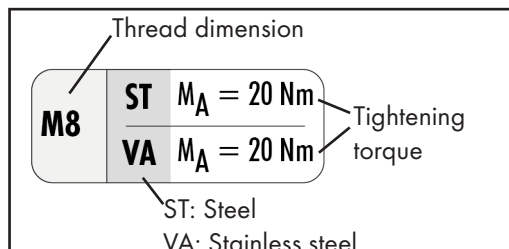

Positioning the cable system

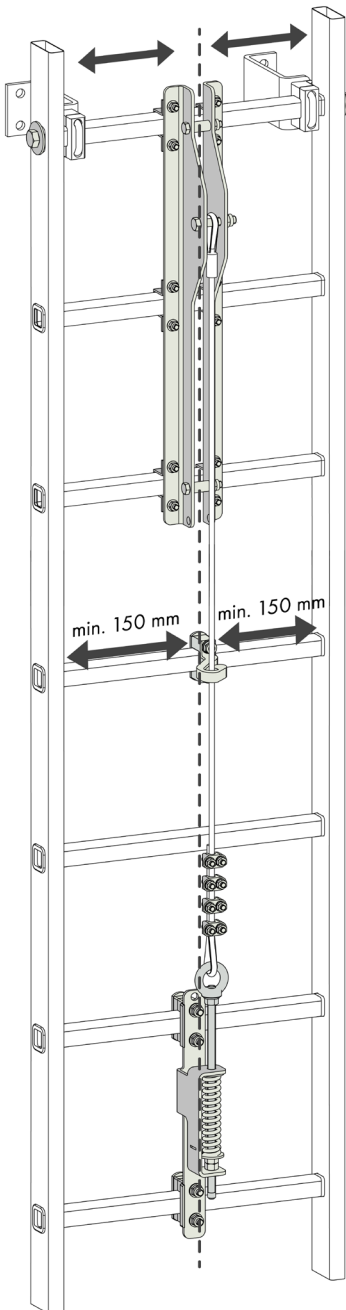

- In order to comply with the prescribed widths of at least 2 x 150 mm on the rung, the cable system must be mounted centrally on the rung.
- When installing the system components, make sure that the fall arrest rope is mounted in a vertical position.

10. Assembly

Install rope suspension at the top – to ladders of Hailo Wind Systems



WARNING!
Only permitted for ladders of Hailo Wind Systems.

- This installation is only allowed for attaching the system to ladders of Hailo Wind Systems.
- For installing on ladders of other manufacturers, see the installation instructions on pages 28 and 29.

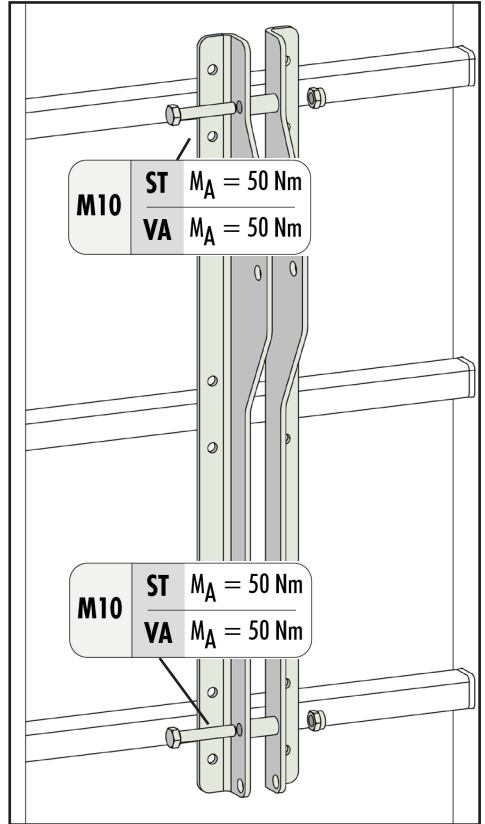
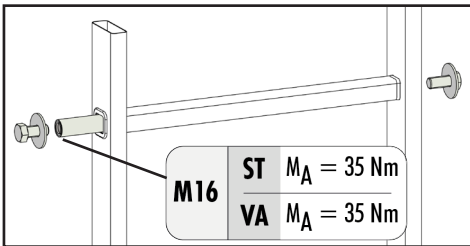

1. Insert the insertion tube into the top rung of the ladder where the rope suspension at the top is to be attached.
2. Place washers on both ladder rails and bolt them on.
3. Bolt on the top and bottom cross-connection of the retaining plates. To do this, thread bolts through spacer sleeves.

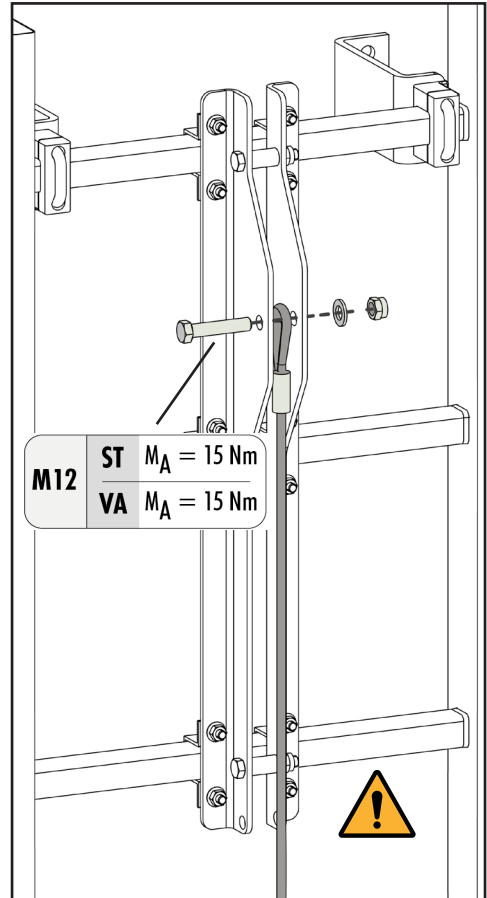
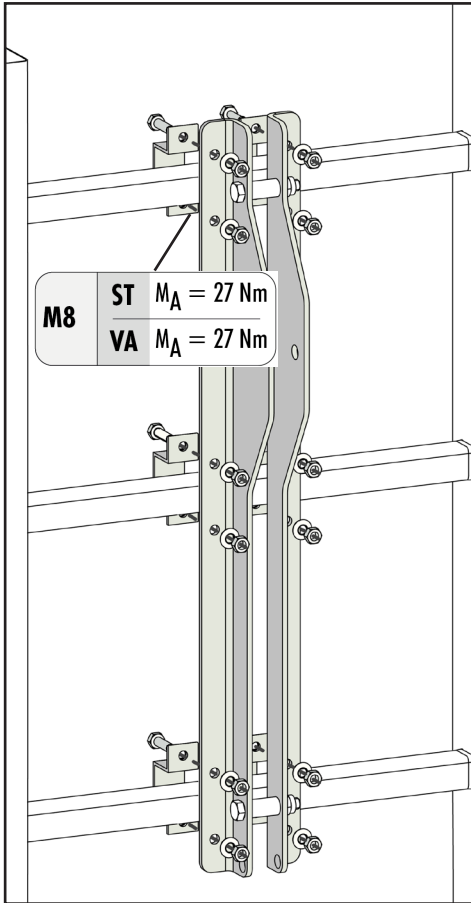

4. Tighten the retaining plates of the rope suspension centrally. To do this, guide the bolts through the rung clamps.

5. Insert and secure the rope thimble in the middle cross connection.

Be sure to guide the rope in front of the cross connection.

Install rope suspension at the top – to ladders of other manufacturers

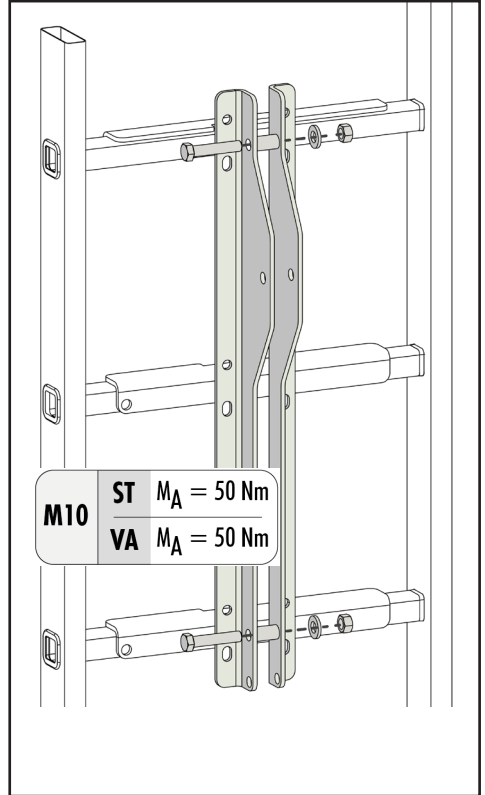
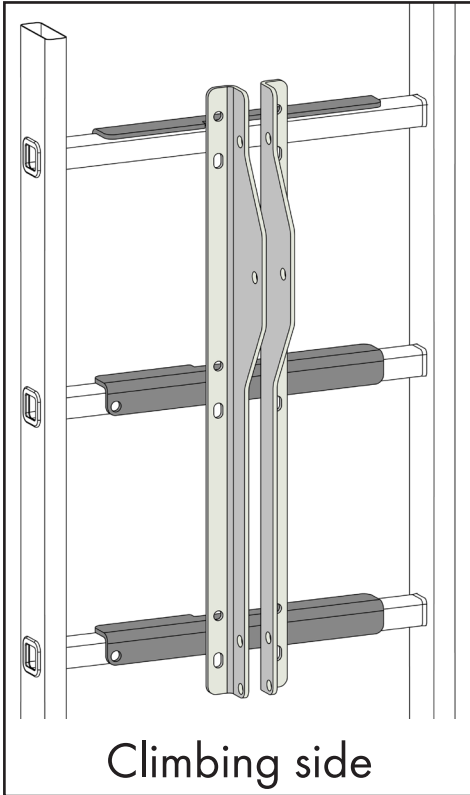

1. Place the rung tabs in the middle of the top three rungs of the access ladder.
Caution: The two lower rung tabs point to the climbing side. The top rung tab is placed facing away from the climbing side.
2. Bolt on the top and bottom cross-connection of the retaining plates. To do this, thread bolts through spacer sleeves.

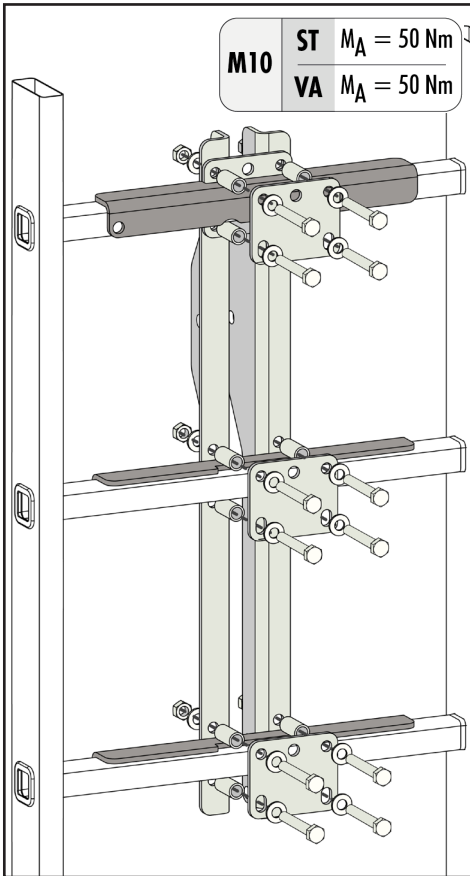

3. Tighten the retaining plates of the rope suspension centrally. To do this, guide the bolts through the rung metal plates and spacers sleeves above and below the rung.
At the top rung, the bolts on both sides of the rung are guided through rung metal plates. The bolts are secured with washers.

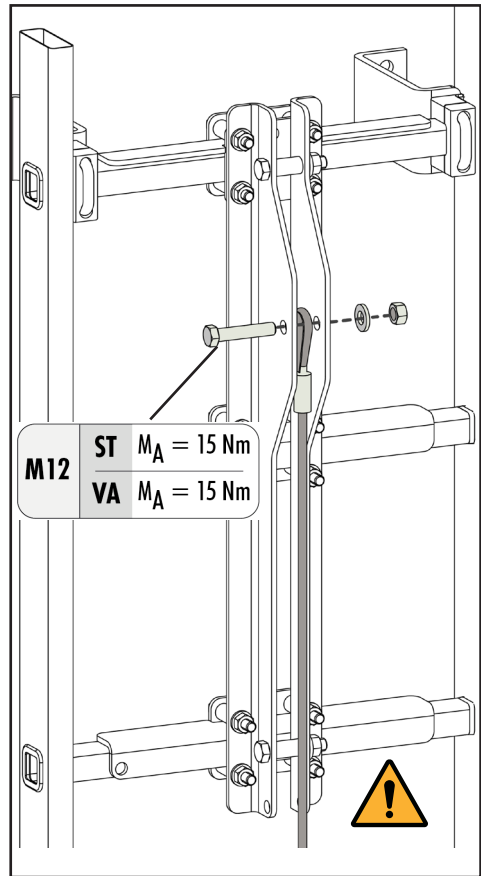

4. Insert and secure the rope thimble in the middle cross connection.

Be sure to guide the rope in front of the cross connection.

10. Assembly

Assembling the rope guide

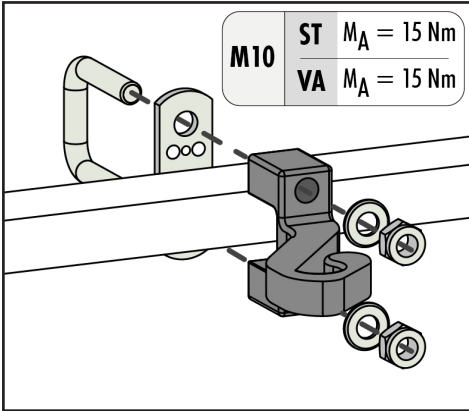

1. Place the rung adapter on the rung so that the rope can run through the guide. Guide the U-bolt through the perforated plate and bolt it to the rung adapter.
2. Push the rope into the cable guide.

Max. distance between the individual cable guides = 9520 mm (every 34th rung with a rung distance of 280 mm).

Assemble rope suspension at the bottom

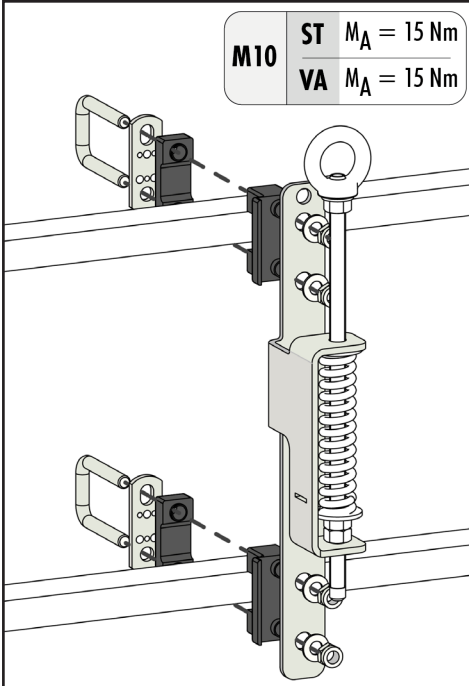

1. Place the rung adapter in the centre of the rung. Guide U-bolt through perforated plate, rung adapter and angle plate and bolt together.

Assembly of the wire rope clamps

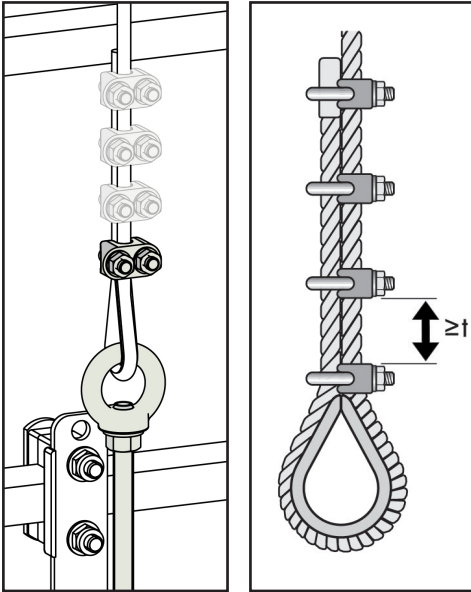

1. Lead the rope through the pre-assembled thimble in the ring nut.
2. Tighten the rope with four rope clamps. The first wire rope clamp is attached close to the thimble. Observe a tightening torque of 6 Nm.

Leave a distance of at least one wire rope clamp width between the wire rope clamps.

Always place the clamps on the unused end of the rope.

3. After the first full load, the tightening torque must be rechecked and readjusted if necessary.

Adjusting the rope tension

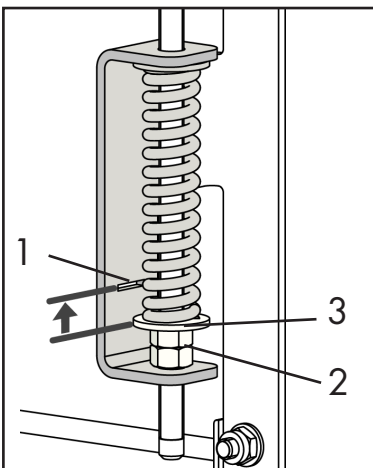

The spring of the rope tensioning device must be tensioned with a clamping force of approx. 800 N.

1. Anchor the rope system securely at the top and bottom ends.
2. When adjusting the rope tension, orient yourself at the provided recess (1) in the angle plate at the bottom of the rope suspension. Tighten the nuts (2) until the washer (3) is flush with the recess.

11. Usage



DANGER!
Observe safety instructions.

- Read the manual carefully before using the fall arrest system.
- Especially observe the safety instructions in the "Safety" section.

11.1 Fall arrester HWS SKC EVO

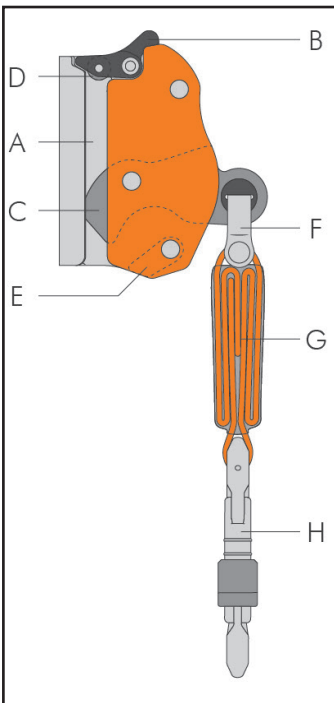

A	Body
B	Locking lever
C	Locking cam
D	Reel
E	Oneway mobile body system (movable)
F	Connector for energy absorber
G	Energy absorber BFD 140FAS8
H	Triple-lock-carabiner

- The fall arrester is to be attached to the fall arrester rope before ascending or descending. The fall arrester HWS SKC EVO accompanying the fall arrest rope is equipped with a energy absorber and is connected to the safety harness of the user.
- The fall arrester HWS SKC EVO is only approved for securing the user.
- The fall arrester HWS SKC EVO complies with the regulations under EN 353-1: 2014.

Fall arrester HWS SKC EVO

Condition and expiry date

- The permanently integrated energy absorber must be replaced depending on the condition and intensity of use. Only the manufacturer may replace the energy absorber.
- The useful life of the components depends on the operating environment, climatic issues, storage conditions and intensity of use. Exceptional situations, such as extreme temperatures, falls, contact with harmful substances, can immediately suspend system functioning.
- The fall arrester HWS SKC EVO has a serviceable life of 10 years.

Use of the fall arrester

- The fall arrester HWS SKC EVO may only be used for ascending or descending the HWS-FAS 8 fall arrest system.
Please observe the operating instructions of the fall arrester beforehand.
- The fall arrester may not be used for work positioning. If work positioning is required, use a separate system.
- Further use of a system that has been stressed by a fall is not permitted. In this case, the fall arrester must be returned to the manufacturer. Repairs to the fall arrester may only be carried out by the manufacturer.

Max. load capacity

- The minimum weight of 50 kg (without tools and equipment) and the maximum weight of 140 kg (including tools and equipment) must be observed when in use.

Daily inspection

Make sure

- that the **metal and plastic parts** show no signs of deformations, cuts, cracks, sharp edges, wear, corrosion and oxidation signs;
- that the **textile parts** and the seams do not show any cuts, abrasions, shreds, wear, corrosion, burns or traces of chemical substances; that the threads are not cut, pulled or loosened and that there are no cracks in the seams of the energy absorber;
- that the **protective cover of the energy absorber** is in perfect condition and allows the inspection of the underlying loop strap;
- that the **locking cam and the locking lever** rotate without hesitation and use the springs to automatically return to the start position;
- that the **connector** can rotate in its own opening of the locking cam without external obstructions;
- that the **cam reel** rotates freely; that the movable body of the Oneway mobile body system can move freely;
- that the used **steel rope** is compatible with the safety catch, is not damaged or iced and is correctly positioned;
- that the locking system of the **carabiner** works correctly;
- that the device is in a well-maintained and perfect **functioning condition**.

Perform a function test of the fall arrester.
Check if the device is blocking securely.

Fall arrester HWS SKC EVO

Functional test of the fall arrester

1. Pull the fall arrester upwards on the carabiner to check whether the fall arrester can slide freely.
2. Then pull down with a jerk. Check if the safety catch immediately locks on the rope.

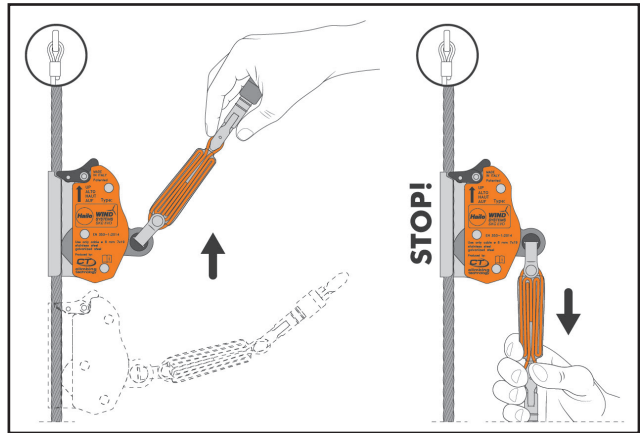

Oneway safety system

The device is equipped with the Oneway safety system: If the device is held upside down, it is not possible to open the locking cam.

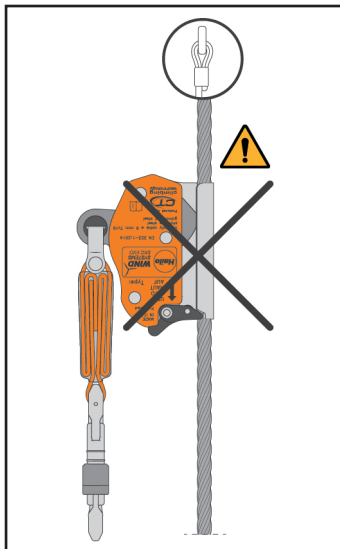

DANGER!
Danger of falling!

- **The fall arrester should not be hung on the rope in the direction opposite the marked direction.**
- Always check if the fall arrester blocks during a functional test.

11. Usage

Implementing the fall arrester

1. Actuate the locking lever, depress as necessary and turn the locking cam until it is fully opened.
2. Position the device on the rope in the correct direction of use, then release the locking cam and the locking lever.

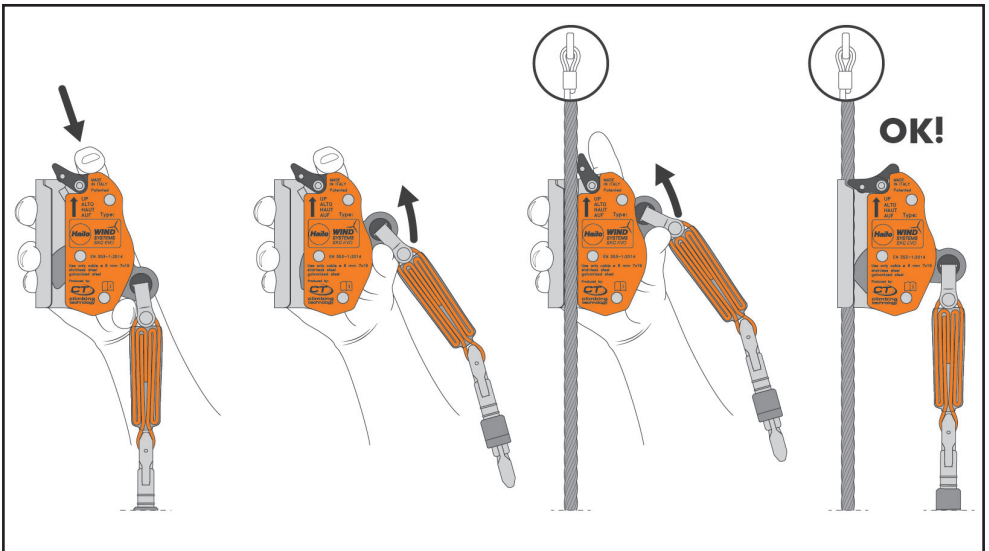

DANGER! Danger of falling!

The fixed guide must be attached and removed from a safe position or with use of a separate fall arrest system.

Fall arrester HWS SKC EVO

Connecting with the belt

1. Attach the triple-lock-carabiner to the sternal fall arrest ring of a full-body harness according to EN 361.



WARNING!

Fall hazard if used incorrectly.

- The snap hook of the energy absorber may only be latched to an approved fall arrest ring of the safety harness.
- The fall arrester HWS SKC EVO must not be connected to the fall arrest rings of the safety harness, which may be present in the hip area as an additional element.
- Connecting elements on the fall arrester may not be lengthened or shortened.

Removing the fall arrester

1. Press the locking lever and open the locking cam as already indicated.
2. Remove fall arrester.

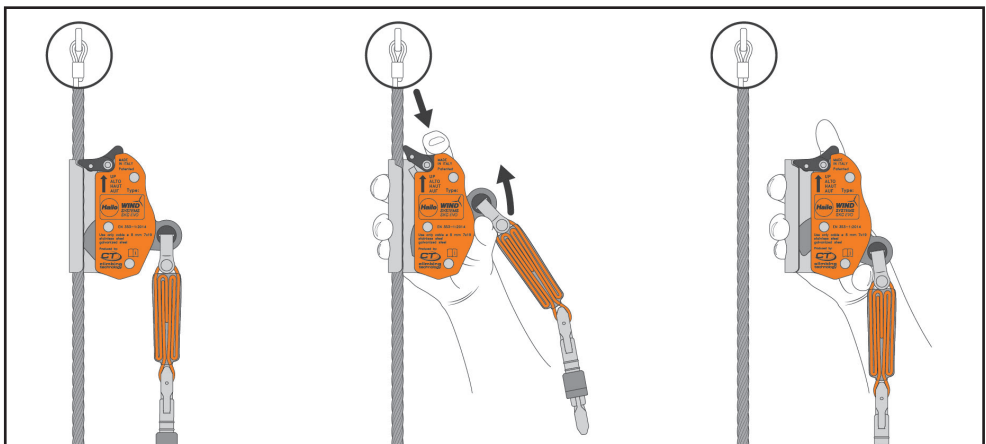

11. Usage

11.2 Ascent and descent

Entering and exiting the fall arrest system

- The fall arrest system is only to be accessed at suitable entry and exit points (i.e., at the beginning and end of the climbing route, on platforms and at attachment points along the climbing route).
- When entering and exiting, the user must be protected from the risk of falling at an approved attachment point or be in a secure position. There should be no risk of falling at any time.
- The user should always choose attachment points or devices that are above them. Check any possible attachment equipment before each use.
- A position where the user is directly on the fall arrester rope over the fall arrester should be avoided. Danger of falling!
- The user must always be below the attachment points.

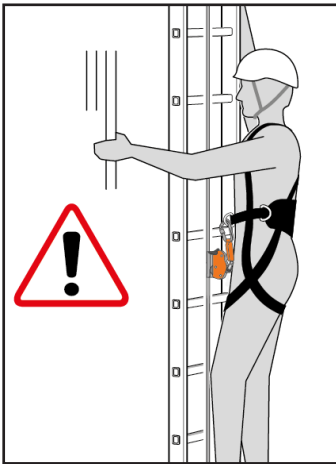

Safe ascent and descent

- During ascent and descent, do not load the rope horizontally backwards.
- Do not use the device for work positioning purposes; instead, use a separate, additional system if necessary.

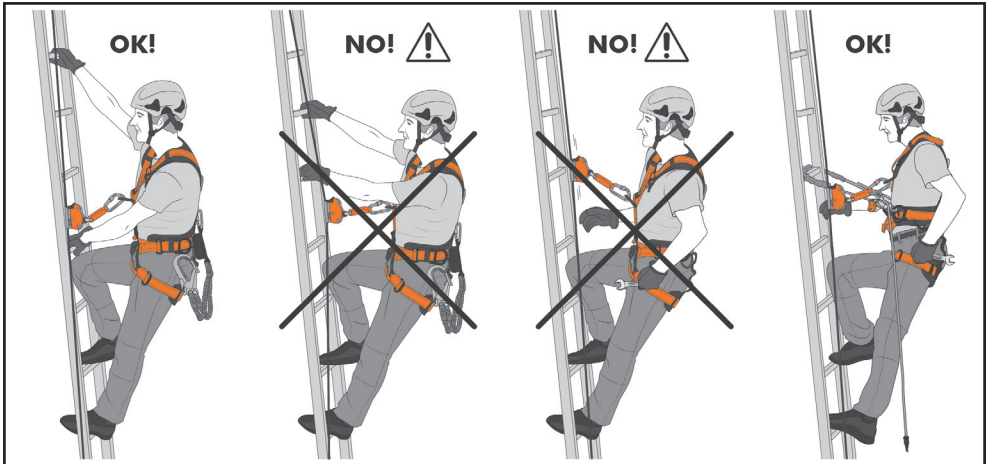

- It is prohibited to extend or shorten the integrated loop of the fall arrester, for example by adding or removing a carabiner. It is also prohibited to replace the fall arrester loop supplied by the manufacturer with a different type of loop.
- During entry/exit, the user should neither touch nor actuate the accompanying fall arrester, since this could cause the braking function to be impaired or even inhibited. Only operate the fall arrester from a secure position.
- The protective effect of fall arrester HWS SKC EVO on the HWS-FAS 8 system is not viable if the user is in the lower area of the climbing equipment (<3 m from the upper edge of the access level).

11. Usage

11.3 Rescue measures

Rescue systems and protective equipment

- The use of personal fall protective equipment is mandatory at work locations that are difficult to reach due to their height or location.
- Personal protective equipment for rescues from heights and depths are components of rescue systems with which persons in an emergency situation can be rescued by pulling out/abseiling up or down. These include, for example: Rescue harnesses, rescue loops, rescue hoists, descent devices, connecting devices, fastening and attachment devices.
- Only approved rescue harnesses may be used. Safety harnesses in accordance with EN 361 can also be used as rescue harnesses. Rescue harnesses must have at least one attachment point for connecting a connecting device or carabiner. These connection points can be two rescue eyelets in the shoulder area, the rear eyelet or the arrester system eyelet. The side eyelets are not approved for rescue operations.

Rules for rescue operations

Please keep yourself informed regarding the employers' liability insurance association rules for safety and health at work (DGUV rules):

- DGUV rule 112-198: Rules for the use of personal fall protective equipment
- DGUV rule 112-199: Rules for rescues from heights and depths with personal protective equipment

Specifications for the operator

- The employer or operating company of an installation must provide a plan in which all possible emergencies that can occur during the use of the fall arrest system are taken into account.
- Before selecting and using personal protective equipment for rescue, the operator must carry out a risk assessment in accordance with section 4 and 5 of the Occupational Health and Safety Act.
- Pursuant to section 2 of the PPE User Regulation, the operator must carry out an evaluation of the equipment available for rescue operations. Only personal protective equipment for rescue operations bearing a CE marking may be selected.

Notice in regard to first-aid measures

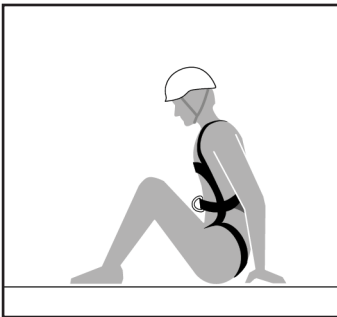

- In the event of a fall, prolonged, motionless hanging in the harness (> 15 minutes) may be associated with significant health risks. There is a risk of hanging trauma (orthostatic shock).

Even if there are no outward signs of injury, the rescued person should be placed in a crouched position (see figure). **Suddenly lying down (into a supine position) can cause acute danger to life through cardiac failure and kidney failure.**



DANGER!

Danger to life due to hanging trauma

- Immediate medical attention and an examination of the injured person to assess their state of health is required in any case.

Notify an emergency physician!

Regular tests



DANGER! **Danger of falling!**

A damaged or poorly maintained system can lead to a fall, resulting in serious injury or death.

For this reason, observe the following:

- Regular inspection of the fall arrest system is mandatory. Before and during use, the fall arrest system must be checked for any damage.
- The system or components of the system are to be withdrawn from use immediately if there are doubts about their safe condition.
- This must occur through the manufacturer or through another competent person.
- In the event of a fall, the system must be inspected immediately by a knowledgeable and qualified person.



NOTICE **Adherence to all scheduled inspections and maintenance**

- It is the responsibility of the operating company to ensure that inspection and maintenance is carried out according to schedule.
- Proof of regular inspection is required for assertion of any warranty claims.
- Additional inspection intervals due to local/operational conditions must be defined by the operator.

12. Inspection and maintenance

Yearly inspection

- **At least once a year**, the access ladder and fall arrest system must be checked for proper condition and functionality. A check is recommended **every 6 months** when used in offshore installations or near coasts. Depending on the frequency and intensity of use, more frequent controls may be necessary depending on environmental conditions.
- This must be done by Hailo Wind Systems or other knowledgeable and qualified personnel.
- The inspection results are recorded on a special sheet which must be enclosed with each system. Do not use the product if the control sheet is missing or illegible.
- The respective national regulations for operation and testing must be complied with.
- The document "Annual Inspection Plan for the Fall Arrester HWS SKC EVO" can be found at <https://www.hailo-windsystems.com/de/downloads>.

Maintenance and repairs

- If components of the fall arrest system, especially the fall arrest rope, are contaminated by concrete dust, sand, dirt or other substances, it can be cleaned with warm water (max 40°C) and an acid-free detergent.
- No acids or alkalis may be used.

13. Assembly log

Assembly log for the HWS-FAS 8 fall arrest system

General information	
Date of installation	
Location	
WTG no.	

Fall protection system	OK	Not OK	Comment
Position for installing the HWS SKC EVO fall arrester: 700 mm – 1200 mm from access level	<input type="checkbox"/>	<input type="checkbox"/>	
Rope suspension TOP (installation according to specifications)	<input type="checkbox"/>	<input type="checkbox"/>	
Rope suspension (properly mounted fall arrester rope, bolts, washers, locknuts)	<input type="checkbox"/>	<input type="checkbox"/>	
Rope suspension BOTTOM (installation according to specifications)	<input type="checkbox"/>	<input type="checkbox"/>	
Fall arrester rope tensioned with spring (according to installation specifications)	<input type="checkbox"/>	<input type="checkbox"/>	
Cable guides mounted (distance \leq 9520 mm, according to installation specifications) Number: units	<input type="checkbox"/>	<input type="checkbox"/>	
Test run with the fall arrester HWS SKC EVO carried out without any problems	<input type="checkbox"/>	<input type="checkbox"/>	

Labelling	OK	Not OK	Comment
Ladder identification plate	<input type="checkbox"/>	<input type="checkbox"/>	
Information sign "Safety distance 3 m"	<input type="checkbox"/>	<input type="checkbox"/>	
Inspection sticker attached	<input type="checkbox"/>	<input type="checkbox"/>	

13. Assembly log

Next inspection	
Company performing services	
Name of assembly manager (in block letters)	
Signature	

Remarks

Specifications for assembly log

- The assembly manager is responsible for proper assembly of the climbing equipment and the HWS-FAS 8 fall arrest system.
- The checklist must be filled out completely by the assembly manager in indelible and legible print.
- The checklist is part of the assembly and must be presented upon request of the manufacturer or a testing institution.

14. Log for inspection

Checkpoints	1st inspection		2nd inspection	
	OK	Not OK	OK	Not OK
Rope suspension BOTTOM: technical condition, tight fit of the bolts	<input type="checkbox"/>	<input type="checkbox"/>	<input type="checkbox"/>	<input type="checkbox"/>
Rope tension acc. specification	<input type="checkbox"/>	<input type="checkbox"/>	<input type="checkbox"/>	<input type="checkbox"/>
Cable guides: technical condition, function, tight fit of the bolts Number: units	<input type="checkbox"/>	<input type="checkbox"/>	<input type="checkbox"/>	<input type="checkbox"/>
Rope suspension TOP: technical condition, tight fit of the bolts	<input type="checkbox"/>	<input type="checkbox"/>	<input type="checkbox"/>	<input type="checkbox"/>
Rope suspension: Condition of bolt, washer, locknut	<input type="checkbox"/>	<input type="checkbox"/>	<input type="checkbox"/>	<input type="checkbox"/>
Fall arrester rope: Corrosion, kinks, loops, wire breaks (2 or more wire breaks on a length of 50 mm)	<input type="checkbox"/>	<input type="checkbox"/>	<input type="checkbox"/>	<input type="checkbox"/>
Rope thimble + compression sleeve: technical condition	<input type="checkbox"/>	<input type="checkbox"/>	<input type="checkbox"/>	<input type="checkbox"/>
Identification complete and legible	<input type="checkbox"/>	<input type="checkbox"/>	<input type="checkbox"/>	<input type="checkbox"/>
Functional test of the fall arrest system and fall arrester	<input type="checkbox"/>	<input type="checkbox"/>	<input type="checkbox"/>	<input type="checkbox"/>
Condition of the fall arrest system	<input type="checkbox"/>	<input type="checkbox"/>	<input type="checkbox"/>	<input type="checkbox"/>
Completed repairs, comment				
Inspected and documented on:				
Next inspection date:				
Inspector and company				
Signature				

14. Log for inspection

Checkpoints	6th inspection		7th inspection	
	OK	Not OK	OK	Not OK
Rope suspension BOTTOM: technical condition, tight fit of the bolts	<input type="checkbox"/>	<input type="checkbox"/>	<input type="checkbox"/>	<input type="checkbox"/>
Rope tension acc. to specification	<input type="checkbox"/>	<input type="checkbox"/>	<input type="checkbox"/>	<input type="checkbox"/>
Cable guides: technical condition, function, tight fit of the bolts Number: units	<input type="checkbox"/>	<input type="checkbox"/>	<input type="checkbox"/>	<input type="checkbox"/>
Rope suspension TOP: technical condition, tight fit of the bolts	<input type="checkbox"/>	<input type="checkbox"/>	<input type="checkbox"/>	<input type="checkbox"/>
Rope suspension: Condition of bolt, washer, locknut	<input type="checkbox"/>	<input type="checkbox"/>	<input type="checkbox"/>	<input type="checkbox"/>
Fall arrester rope: Corrosion, kinks, loops, wire breaks (2 or more wire breaks on a length of 50 mm)	<input type="checkbox"/>	<input type="checkbox"/>	<input type="checkbox"/>	<input type="checkbox"/>
Rope thimble + compression sleeve: technical condition	<input type="checkbox"/>	<input type="checkbox"/>	<input type="checkbox"/>	<input type="checkbox"/>
Identification complete and legible	<input type="checkbox"/>	<input type="checkbox"/>	<input type="checkbox"/>	<input type="checkbox"/>
Functional test of the fall arrest system and fall arrester	<input type="checkbox"/>	<input type="checkbox"/>	<input type="checkbox"/>	<input type="checkbox"/>
Condition of the fall arrest system	<input type="checkbox"/>	<input type="checkbox"/>	<input type="checkbox"/>	<input type="checkbox"/>
Completed repairs, comment				
Inspected and documented on:				
Next inspection date:				
Inspector and company				
Signature				

Comments

Comments

Hailo Wind Systems GmbH & Co. KG

Kalteiche-Ring 18 • 35708 Haiger • Germany

Phone: +49 (0) 2773 82-0 • Fax: +49 (0) 2773 82-1561

E-mail: info@hailo-windsystems.com • www.hailo-windsystems.com