

HIGH LEVEL ACCESS SOLUTIONS



**ALUMINIUM FIXED LADDERS 60X20**  
**IN WIND TURBINE GENERATORS AND MACHINE INSTALLATIONS**  
**DIN EN ISO 14122-4:2016**  
Assembly and operating instructions - Original document

EN  
2021-08  
1121569  
V02R00

### Legal notice

Contact: Hailo Wind Systems GmbH & Co. KG  
Kalteiche-Ring 18  
D-35708 Haiger  
Germany

Phone: +49 (0) 2773/82-1410

Fax: +49 (0) 2773/82-1561

E-mail: [info@hailo-windsystems.com](mailto:info@hailo-windsystems.com)

Internet: [www.hailo-windsystems.com](http://www.hailo-windsystems.com)

© Hailo Wind Systems – Without the prior written consent of Hailo Wind Systems, no part of this publication may be reproduced in any way, transmitted, transcribed, stored in a storage medium or translated into any language or computer language. Copyright infringement may also affect the product support by Hailo Wind Systems for this equipment. Hailo Wind Systems reserves the right to make changes to this manual and the product it describes without prior notice. The content of this manual does not include any contractual or other obligations by Hailo Wind Systems and is not legally binding. This publication was prepared with great care. However, should you find any errors or wish to make suggestions for improvement, please write to Hailo Wind Systems. The original language of this document is German. If required, you can request a copy in writing.

## Contents

1	About This Document.....	5
1.1	Classification of the warnings.....	6
2	General instructions.....	7
2.1	Standards and regulations.....	7
2.2	Transport and storage.....	7
	Storage conditions.....	7
3	Safety.....	9
3.1	Intended use.....	9
3.2	Foreseeable misuse.....	10
3.3	Safety instructions.....	11
3.4	Markings and information.....	15
	Access ladder type plate.....	15
	Ladder identification plate.....	15
4	System overview.....	16
4.1	Ladder with fall protection rail (DIN EN 353-1:2018).....	16
4.1.1	Ladder fastenings.....	16
4.1.2	Ladder connectors.....	17
4.1.3	Base anchor.....	18
4.1.4	Rest platform.....	18
4.1.5	Rung repair kit.....	18
5	Assembly.....	19
5.1	General assembly instructions.....	19
5.2	Technical specifications.....	21
5.2.1	Fastener.....	21
5.2.2	Ladder entry dimension and ladder exit dimension.....	25
5.2.3	Entry and exit elements.....	27
5.2.4	Minimum tread depth and wall clearances.....	28
5.2.5	General screw tightening torques (unless otherwise specified).....	30
5.3	Wall brackets.....	31
5.4	Ladder connectors.....	33
5.5	Rung repair kit.....	40
5.6	Base anchor.....	41
5.7	Rest platforms.....	42

5.8	Potential equalisation .....	44
6	Usage.....	46
6.1	Daily inspection .....	46
7	Inspection and maintenance .....	48
7.1	Yearly inspection .....	48
7.2	Maintenance and repairs.....	48
8	Assembly log .....	49
9	Test report.....	52

## 1 About This Document

### Preface



*This information brochure  
in other languages*

These assembly and operating instructions describe the installation, use, maintenance and testing of the aluminium access ladder system.

#### NOTE

Please read these instructions in their entirety and observe all safety information before you begin assembly work and use the access ladder. Hailo Wind Systems will not assume any liability caused by failure to observe these instructions and the safety warnings.

These assembly and operating instructions are only valid for access ladder systems of Hailo Wind Systems.

#### NOTE

If the climbing system is resold to a buyer in another country, it is necessary for the safety of the user that this manual be made available in the respective national language. Translations can be requested from: [documentation@hailo-windsystems.com](mailto:documentation@hailo-windsystems.com).

#### ATTENTION!

Hailo Wind Systems reserves the right to make technical modifications and improvements which do not apply to the tested prototype in regard to safety-relevant criteria. Hailo Wind Systems reserves the right to make changes to the content of the technical documentation.

# About This Document

## 1.1 Classification of the warnings

### *Classification of the warnings*

Warnings are introduced by signal words that express the extent of the hazard. A distinction is made between four types of warnings:

#### **DANGER!**

DANGER indicates an imminently threatening dangerous situation which could lead to serious injuries or death if not avoided.

#### **WARNING!**

WARNING indicates a potentially dangerous situation which could lead to serious injuries or death if not avoided.

#### **CAUTION!**

CAUTION indicates a potentially dangerous situation which could lead to minor injuries if not avoided.

#### **ATTENTION**

ATTENTION indicates a possible dangerous situation which could lead to property damage if not avoided.

### *Presentation of important information:*

#### **NOTE**

This symbol is used to draw your attention to important, useful or helpful information.

## 2 General instructions

### 2.1 Standards and regulations

- **OSHA 1910.23**
- **OSHA 1926.1053**
- **ANSI 14.3 (Parts)**
- **AS 1657**  
certified by MTS
- **EN ISO 14122-4:2016**  
Safety of machinery - Permanent means of access to machinery - Fixed access ladders
- **BGV / GUV-V A1**  
Basic principles of prevention
- **DGUV 208-032**  
Selection and use of access ladders
- **DGUV 312-906**  
Selection, training and certification of experts on personal fall protection equipment
- **DIN EN 50308**  
Wind turbines - Protective measures - Requirements for design, operation and maintenance
- **Fall protection requirements**  
According to DIN EN ISO 14122-4: 2016, a falling height  $\geq 3$  m requires fall protection.  
According to DIN EN ISO 14122-4: 2016, for climbing heights over 10 m and a single strand version of the ladder, only fall protection conforming to DIN EN 353-1: 2018 is permitted.
- **Fall protection requirements**  
The fall arrest system must comply with DIN EN 353-1: 2018. The access ladder shall be equipped with a fall arrest system including a fixed guide. Observe national regulations.
- **Arrangement for access and exiting with access ladders and fall arresters**  
The fall arrester and its surroundings must be arranged so that users attach or release themselves from a secured position, for example, through the provision of an attachment point conforming to DIN EN 795 or a trapdoor, which leads to a completely protected platform with self-closing barrier gate according to DIN EN ISO 14122-3:2016, 7.4.

### 2.2 Transport and storage

All parts of the system must be secured so that their function is not incurred and all components are in perfect condition in terms of safety.

#### Storage conditions

- The permitted temperature range for use of the access ladder is between - 40 °C and +60 °C.

## General instructions

- Move and load components of the access ladder system with caution.
- To prevent damage, do not turn the ladder components on their sides during transport and storage.
- Do not place additional loads on system components during transport and storage.
- The permitted storage temperature is between  $-40\text{ °C}$  and  $+60\text{ °C}$ .
- During transport and storage, protect components of the access ladder system against wetness, exhaust gases, chemicals or other harmful substances.



### **ATTENTION!**

- Before assembling the access ladder system, check that all components are in perfect condition.
- System components must not have been damaged during transport.
- Damaged parts must be replaced before assembly.



## 3 Safety

### 3.1 Intended use

The fixed access ladder is specially designed for use in wind turbine generators and machine installations. It is used to ensure the safe ascent and descent of service personnel from workplaces at height.

The person using the ladders connects their personal fall protection equipment (PFPE) to the fall arrest system that runs along the entire length of the ladder.

If a person is not secured, for example on the fall arrest system, the ladder may not be used.

The employer or operating company of an installation must provide a plan in which all possible emergencies that can occur when using the access ladder system are taken into account and the necessary rescue measures are explained.

The access ladder may only be used if it is in perfect condition.

These assembly and operating instructions must be observed by all persons who install and use the access ladder.

The fixed access ladder may only be installed by trained persons.

The precondition for safe handling as well as faultless assembly and use of the access ladder is compliance with the safety instructions and regulations.

Structural modifications are only possible after receiving approval by Hailo Wind Systems. A copy of the approval must then be added to the technical documentation (manual).

The fixed access ladder may only be used by persons who have been instructed in the use of the access ladder and fall arrest system, and who are familiar with the safety plan in the wind turbine generator or machine installation.

This includes any necessary rescue measures along with their initiation and implementation. The accident prevention regulations applicable to the respective installation site as well as the safety regulations listed here are to be followed.

The operator of the wind turbine generator must ensure that unauthorised persons cannot access the ladder.

## 3.2 Foreseeable misuse

The ladder may only be used for its intended purpose.

Non-intended use is prohibited and may lead to failure of individual components and thus to failure of the entire system.

The ladder may not be used in the following cases:

- Incorrect assembly
- Safety defects or incorrectly performed repairs
- Unauthorised or unapproved modifications to the climbing equipment
- Non-original spare parts
- Insufficiently qualified personnel
- Unfamiliarity with or failure to observe these assembly and operating instructions
- Inadequate maintenance and care or neglect of timely inspection of the access ladder system

### **NOTE**

No liability will be assumed for harm to persons or damage to equipment arising from violation of the provisions stipulated here or failure to observe the safety instructions.

### 3.3 Safety instructions



#### ATTENTION!

Failure to follow these instructions may result in property damage.

Therefore:

- Read these instructions carefully and keep them in mind before using the access ladder system.
- The access ladder system with fall arrester may only be performed assembled and used by persons who have been instructed and authorised by the manufacturer.
- The operator must ensure that these assembly and operating instructions are kept on site with each access ladder system and are available to personnel.



#### ATTENTION!



#### Wear personal fall protection equipment!

Protection against falls from above a minimum height.



#### Carry along a communication device (mobile phone, radio unit)

When in or on the wind turbine generator, constant voice contact must be ensured between the people involved. Ensure contact between persons using mobile phones or radios.



#### Wear a helmet

Head protection against falling objects and impacts from falls or in confined spaces.



#### Wear safety footwear

Foot protection against heavy falling objects, slipping, or stepping on sharp-edged parts that are lying around.



#### Wear safety gloves

Hand protection against friction, abrasions, stabs and cuts.



## **DANGER!**

**Disregarding the safety instructions may result in a fall and therefore lead to serious injury or death.**

Therefore:

- Before using the ladder, secure your personal fall protection equipment (PFPE) to the fall arrest system provided.
- The personal fall protection equipment must be properly selected, used and checked.
- The access ladder system must not be used in icy conditions.
- In pylon towers, the ladder may not be used in extreme temperature and weather conditions (e.g. hail, strong wind, snow and ice).

Do not use the ladder if you feel unwell or are in poor physical condition.

- Make sure there are no objects or equipment under the ladder that could pose an additional hazard in the event of a fall.
- There must not be any oil, grease or other lubricants on surfaces for walking or climbing on.
- Do not exceed the maximum permitted payload of 150 kg in a ladder section between two wall brackets.
- If there are doubts about the safe condition of the system or any parts of it, they must be immediately taken out of use.



## **DANGER!**

**Risk of injury from electric shock!**

**Improper operation may cause serious injury or death.**

Therefore:

The ladder must be earthed along its entire length (equipotential bonding)!

The ladder must not come into contact with electrical cables or components that are damaged or not suitably insulated.



## DANGER!

**Improper operation may cause serious injury or property damage.**

Therefore:

- The ladder may only be used by trained personnel.
- Damaged components may only be replaced by specialist personnel (authorised by the manufacturer) using genuine parts. A change or extension of the access ladder system may not be undertaken without the explicit prior written approval of the manufacturer. A copy of the approval must then be added to the technical documentation (manual). Any necessary repairs must be carried out in accordance with the procedures specified by the manufacturer.
- Never disable the safety equipment.
- Keep everything clean and tidy! Loosely stacked or scattered objects such as tools, cables and components are sources of accidents.



## WARNING!

**Property damage possible due to non-compliance with safety instructions**

Observe the safety regulations for wind turbines as well as the instructions issued by the turbine manufacturer.



## ATTENTION!

**Inspection and maintenance intervals**

- Observe the prescribed intervals for regular inspections/maintenance!
- The proper condition of the ladder and the attachment points must be checked at least once a year by a competent and qualified person.
- The checklist for the inspection can be found in the appendix to these instructions.



## NOTE

### Language of the manual

If the system is resold to a buyer in another country, it is necessary for the safety of the user that this manual be made available in the respective national language. Translations can be requested from:  
[documentation@hailo-windsystems.com](mailto:documentation@hailo-windsystems.com)

## 3.4 Markings and information

**Aluminiumladder**  
Aluminium ladder

Type Type	60 x 20 mm
Material Material	Aluminium
Sport Rail	60 x 20 mm
Sporten Rungs	30 x 30 mm
Ladder- breedte Ladder width	470 / 490 / 520 mm
Toegestane belasting Permitted load	Gewicht = 150 kg Weight = 330 lbs

**Neem de montagehandleiding in acht.**  
Please comply with the operating instructions.

**Certificaatnr.**  
**5017033.17002**

Ladder gecertificeerd conform:  
Ladder certified according to:

• EN ISO 14122-4: 2016

Geldig alleen in combinatie met Hailo montage- en bevestigingscomponenten.  
Only valid in conjunction with Hailo mounting and fixing components.

Ladder stemt ook overeen met:  
Ladder also complies with:

- OSHA 1926.1053 • ANSI 14.3 (Parts)
- OSHA 1910.23

**Productiejaar**  
Year of construction  
**2021**

Hailo Wind Systems GmbH & Co. KG  
Kaltelche-Ring 18 • D-35708 Haiger  
Germany  
www.hailo-windsystems.com  
1156219 • 01/2021

**Fixed ladder**

Aluminium ladder 72x25  
Aluminium ladder 60x20

Rail:	72 x 25 mm or 60 x 25/20 mm
Rungs:	30 x 30 mm
Ladder width:	450 - 520 mm
Maximum load on rungs:	150 kg/ 330 lbs
For Canada:	90 kg with a safety factor of 4
Temperature limits:	-40°C - +60°C

---

**Europe:**  
ISO 14122-4:2016

---

**USA:**  
OSHA 29 CFR 1910.23  
OSHA 29 CFR 1926.1053  
ANSI 14.3 (parts)

---

**Canada:**  
Québec S-2.1,r.13 article 23  
Ontario 213/91 article 78

---

**Australia:**  
AS 1657  
certified by MTS

---

**China:**  
GB 17889

---

Hailo Wind Systems GmbH  
& Co. KG  
Kaltelche-Ring 18 • D-35708  
Haiger Germany  
www.hailo-windsystems.com  
1147519 • 04/2020 • EN

### Access ladder type plate

- Manufacturer, type designation
- Material and dimension specifications
- Instructions on access ladder loads

### **i** NOTE

### Labels on the fixed access ladder

Pay particular attention to all labels or stickers with safety instructions.

**ACHTUNG!**

Aufstieg nur mit einem zum Führungsseil oder zur Führungsschiene zugelassenem Auffanggerät. Nur Auffanggürte der Standards EN 361 (Europa), OSHA/ANSI (Nordamerika), AS/NZS 1891.1:2007 (Australien, Neuseeland) oder NBR 15.836 (Brasilien) verwenden!

**ATTENTION!**

Ascend only using a fall arrester suitable for the guiding cable or guide rail. Use only safety harnesses acc. to EN 361 (Europe), OSHA/ANSI (North America), AS/NZS 1891.1:2007 (Australia, New Zealand) or NBR 15.836 (Brazil).

**ATTENTION!**

Ne montez sur l'échelle que si elle est munie d'un système antichute adapté au câble ou au rail de guidage. Utilisez exclusivement des harnais de sécurité aux normes EN 361 (Europe), OSHA/ANSI (Amérique du Nord), AS/NZS 1891.1:2007 (Australie, Nouvelle-Zélande) ou NBR 15.836 (Brésil).

Zulässige Belastung  
Gewicht = 150 kg  
Permitted load  
Weight = 150 kg  
Charge max. autorisée  
Poids = 150 kg

**DIN EN 353-1:2018**  
**AS/NZS 1891.3:1997**  
**ABNT NBR 14.627/2010**  
**ANSI Z359.16-2016**

**Leiter entspricht:**  
Ladder complies to:  
L'échelle satisfait aux normes:

**OSHA 1926.1053**  
**OSHA 1910.23**  
**ANSI 14.3 (Parts)**  
**EN ISO 14122-4: 2016**  
**AS 1657 (nur/only/seul 72x25 & 60x20)**

Zugang nur für im Steigschutz unterwiesene Personen.  
Access only permitted for persons trained in fall protection.  
Accès réservé aux personnes au courant du système antichute.

Montiert  
Assembled  
Monté

Nächste Prüfung  
Next inspection  
Prochaine inspection

1802179 - 12/2019

### Ladder identification plate

- Notes on the fall arrester system
- Inspection stickers for the yearly inspection by an expert
- Instructions on access ladder loads

## 4 System overview

### 4.1 Ladder with fall protection rail (DIN EN 353-1:2018)

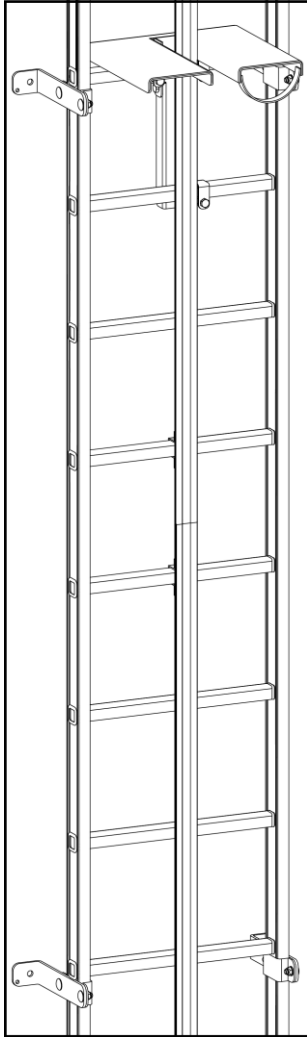

#### **i** NOTE

##### Scope of delivery

All illustrations are examples and deviations from the depictions may arise, depending on the version.

- Aluminium access ladder
- 60x20 mm rail profile

#### 4.1.1 Ladder fastenings

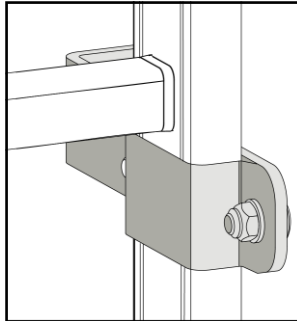

Ladder fastening with rail clamp

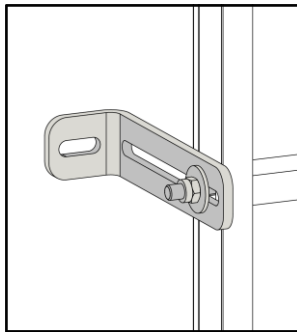

Ladder fastening with threaded rod through rung

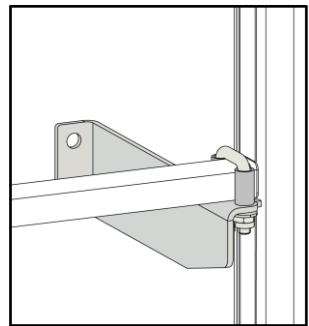

Ladder fastening on wall bracket with U-bolt



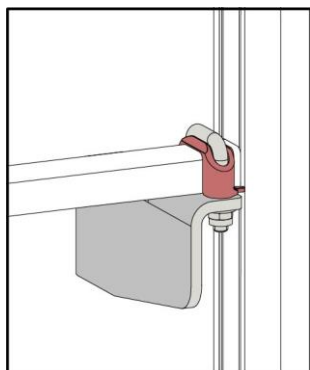

Ladder fastening with rung adapter

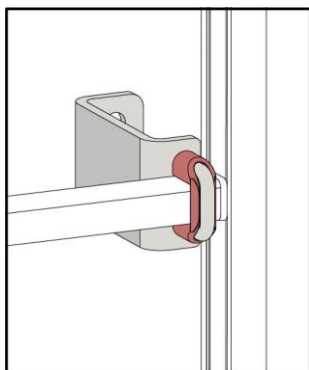

Ladder fastening with rung adapter

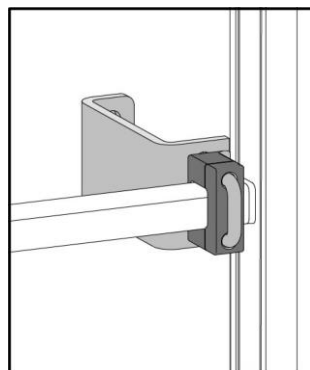

Ladder fastening with rung adapter

## 4.1.2 Ladder connectors

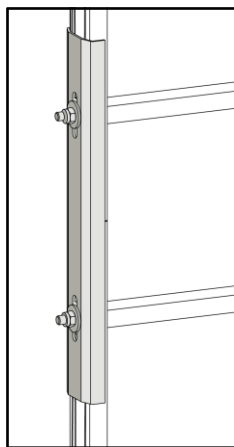

External rail connector

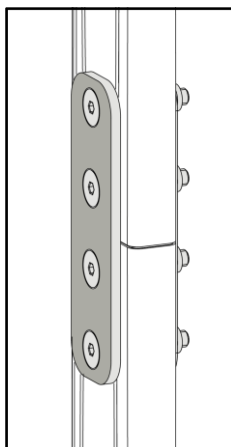

External rail section connector

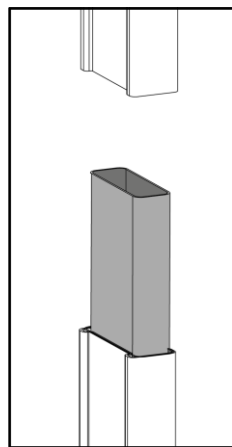

Inner rail connector, aluminium, 60 x 20

## System overview

### 4.1.3 Base anchor

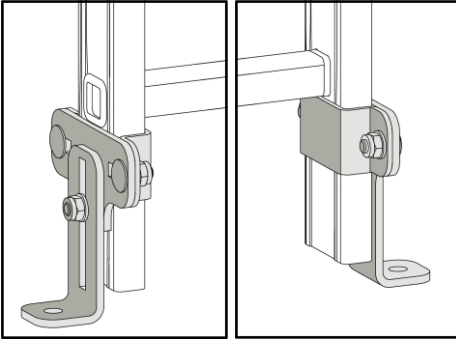

Base fastening with rail clamp

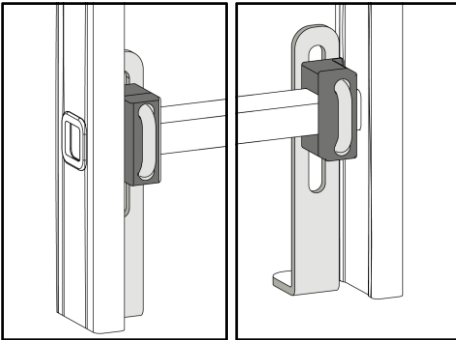

Base fastening on ladder rung

### 4.1.5 Rung repair kit

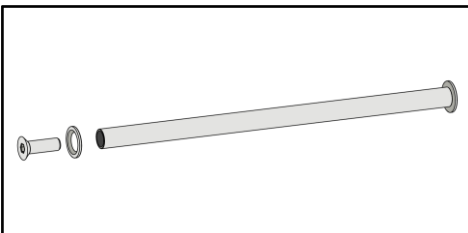

Rung repair kit

### 4.1.4 Rest platform

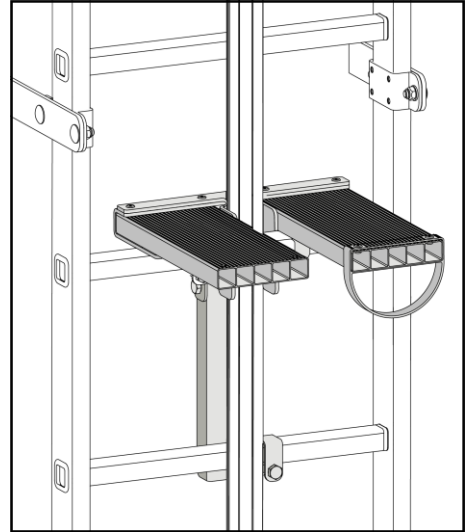

Rest platform SP 305 x 140

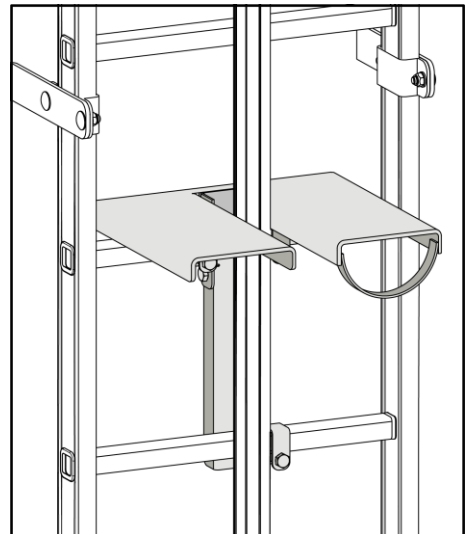

Rest platform with divided treading surface

## 5 Assembly

### 5.1 General assembly instructions

#### ***Proof of load-bearing capacity***

Before commencing assembly, ensure that the expected loads can be borne by the supporting structure. If no relevant information or documentation is available for this, a structural certification must be produced, which takes the required load-bearing capacity into account. If the necessary certifications of safe absorption of forces on the supporting structure are not kept, Hailo Wind Systems shall assume no liability for cases of damage.

#### ***Assembly personnel***

The personnel handling the assembly of the access ladder system must be qualified, competent and have received the respective training.

More detailed information on service trainings can be found under [www.hailo-windsystems.com/sara](http://www.hailo-windsystems.com/sara).

#### ***Safety of the assembly personnel***



### **DANGER!**

#### **Danger of falling.**

**When performing assembly work at height, falling can lead to injuries.**

Therefore:

- Always use your complete PFPE!
- Use an approved fall protection system during assembly.
- Use an approved attachment point as specified in DIN EN 795 or CEN/TS 16415.
- The assembly personnel may not be secured to the system to be installed.

# Assembly

## Assembly and start up

Use only clean and undamaged system parts. Damaged parts must be replaced with new original parts. This may only be carried out by specialist personnel (authorised by the manufacturer). Any necessary repairs must be carried out in accordance with the procedures specified by the manufacturer. The access ladder system may not be modified or extended without the explicit prior written consent of the manufacturer. A copy of the approval by Hailo Wind Systems must then be added to the technical documentation (manual).

## the assembly log

The assembly of the access ladder system must be fully documented by the assembly manager of the assembly company. To do this, fill in the assembly log in the last section of these instructions completely.

## Assembly specifications

The design and version of the ladder must conform to the standard DIN EN ISO 14122-4:2016.

## Specification of tightening torques

Example tightening torque specification

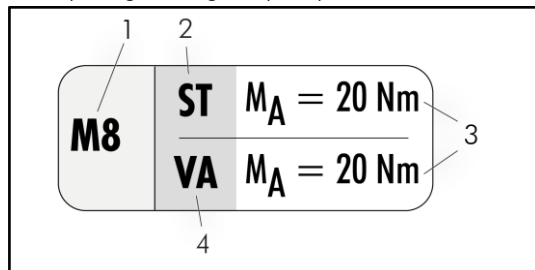

- 1 Thread dimension
- 2 ST: Steel
- 3 VA: Stainless steel
- 4 Tightening torque

## Compatibility with service lifts

All standard service lifts from Hailo Wind Systems can be used on the ladders.

## 5.2 Technical specifications

### 5.2.1 Fastener

#### *Spacing of anchoring points for wall brackets*

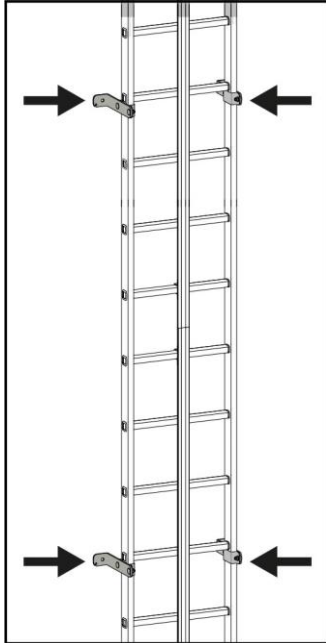

**Loads to be transferred**

The expected loads must be distributed safely on the supporting structure over at least 4 anchoring points per ladder, or at least 2 per side rail. The anchoring points must be arranged in pairs at a single level.

When setting the anchoring points, Hailo Wind Systems recommends that a vertical distance of 2000 mm not be exceeded. For a rung spacing of 280 mm, a distance of 1960 mm is suitable.

Larger distances are to be agreed in advance with Hailo Wind Systems.

#### **! ATTENTION!**

#### **Specifications for use of a fall arrest system**

- When using a fall arrest system according to DIN EN 353-1: 2018, static loads of 15 kN must be taken into account.
- When using a fall arrest system, the national regulatory requirements must also be observed.

The anchoring points and their connections (brackets, fixing devices) must be capable of bearing the respective loads.

The loads of 15 kN per wall bracket spacing (7.5 kN per side rail) must be taken into account. This corresponds to a load of up to 3.75 kN per anchoring point.

Other factors to consider include: weight of the access ladder installation, maximum number of persons on the ladder, load in the event of a fall.

## Assembly

### **First wall bracket**

The fit of the first wall bracket pair depends on the type of ladder fastenings.

The specifications can be waived if the ladder is fixedly bolted to the ground with a base anchor.

### **Ladder fastening with rail clamps**

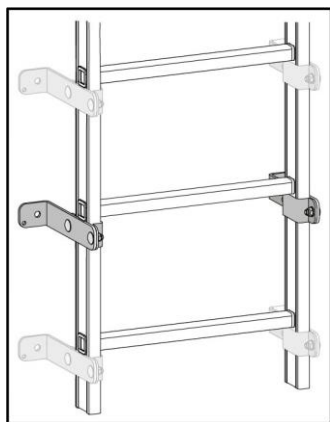

The first wall bracket is attached under the first rung, between the first and second or between the second and third rung.

### **Ladder fastening with rung adapter and fastening with threaded rod through the rung**

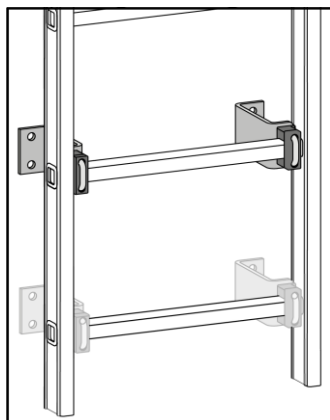

The first wall bracket is attached on the first or second rung.

## Last wall bracket

The fit of the last wall bracket pair depends on the type of fall arrest system used and the type of ladder fastenings.

Larger distances between the last wall bracket pair and the end of the ladder must be agreed with Hailo Wind Systems.

The ladder can extend even further beyond the top fastening of the arrester system as long as the attachment specifications are still met.

## Ladder fastening with rail clamps

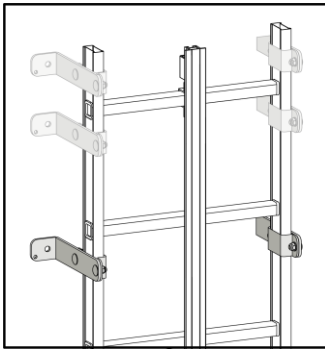

### Fall protection with rail or ladder without arrester system:

The last wall bracket is attached above the first rung, between the first and second or between the second and third rung from the top.

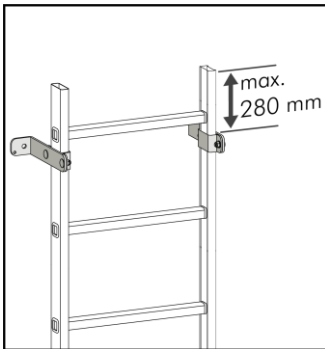

### Fall arrester with rope guide:

The last wall bracket may lie maximally 280 mm under the end of the rail.

### **Ladder fastening with rung adapter and fastening with threaded rod through the rung**

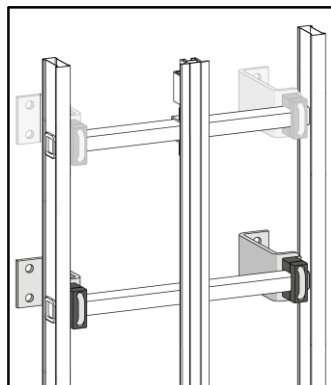

**Fall protection with rail or ladder without arrester system:**

The last wall bracket is attached on the first or second rung from the top.

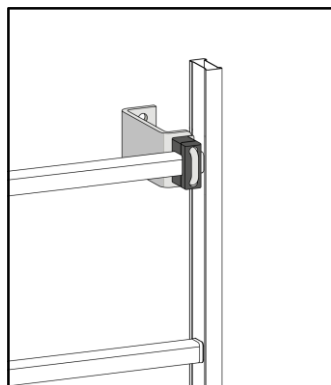

**Fall arrester with rope guide:**

The last wall bracket is attached on the first rung from the top.



## 5.2.2 Ladder entry dimension and ladder exit dimension

### Ladder entry dimension

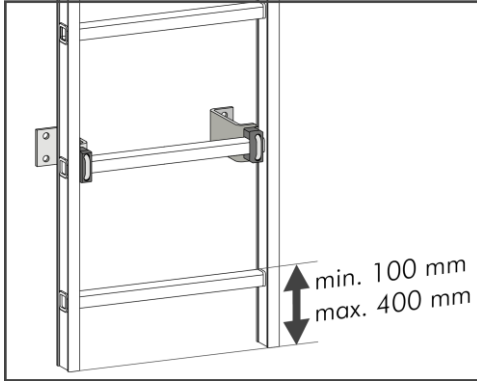

The distance between the entryway surface (e.g. the ground) and the top of the lowest rung must be more than 100 mm and less than 400 mm (per DIN EN ISO 14122-4: 2016).

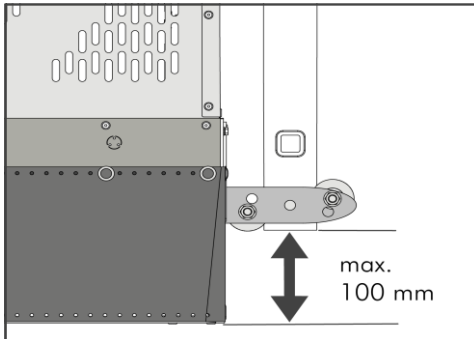

If a service lift of Hailo Wind Systems is operated on the ladder, the distance between the ladder rail end and the ground may not be more than 100 mm.

## Assembly

### Ladder exiting dimension

The upper edge of the top rung must be at the same height as the stepping area of the exit surface.



### ATTENTION!

#### Specifications for wall clearance at ladder exit According to DIN EN ISO 14122-4:2016

The distance between rung and stepping area at the ladder exit may be maximally 75 mm.

#### Wall clearance at ladder exit

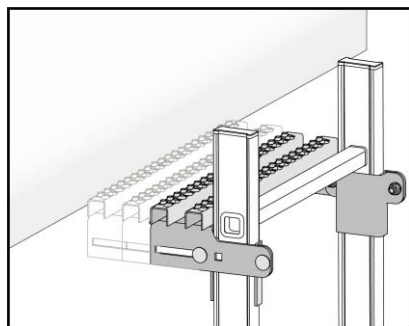
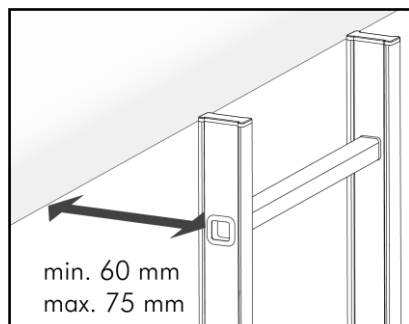

If necessary, an exit extension should be attached. This is bolted with a rail clamp underneath the last rung. Deviating versions/sizes are possible.

Wall bracket clearance	Number of rungs of the exit extensions
165-215 mm	2
215-290 mm	3
290-365 mm	4
364-440 mm	5

## 5.2.3 Entry and exit elements

As a safety element for crossing over at the upper end of the climbing route, entry and exit elements can be used. At the ladder crossing point, an additional attachment point must be provided.

If additional components such as entry and exit elements, railings, barrier gates, trapdoors or platforms are used, these must correspond to the standards (DIN EN ISO 14122-3: 2016 and DIN EN ISO 14122-2: 2016).

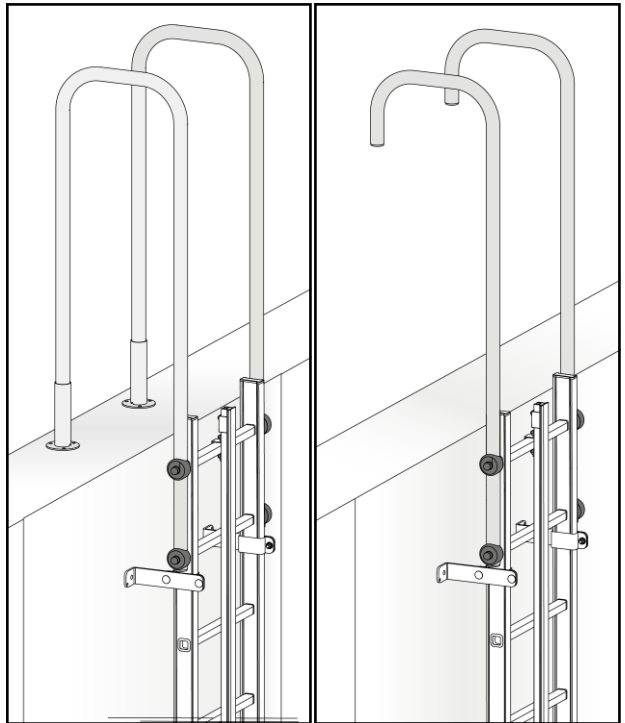

Long exit rail, material:  
stainless steel or galvanised  
steel

Short exit rail, material:  
stainless steel or galvanised  
steel

## 5.2.4 Minimum tread depth and wall clearances

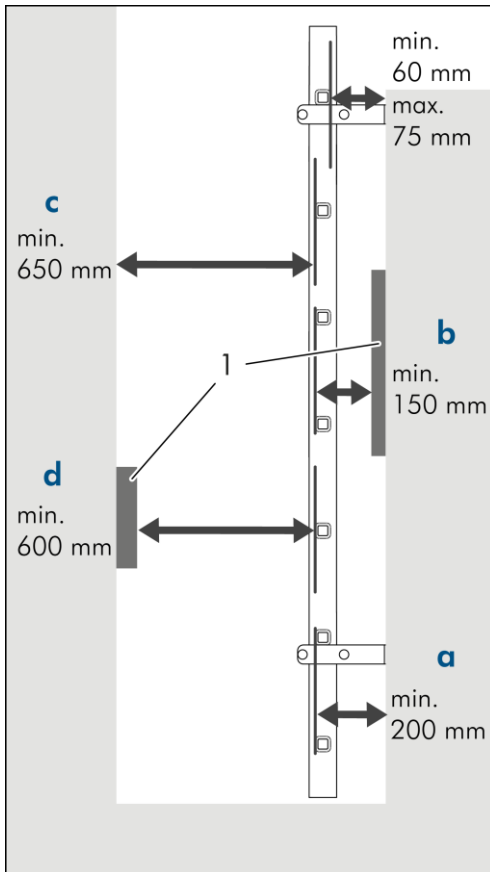

### ! ATTENTION!

#### Observe the minimum tread depth

- The distance from the rung front edge to the fixing surface must be at least 200 mm.
- If there are obstacles [1] (e.g. tower flange) behind the access ladder, the distance from the front of the rung to the fixing surface must be at least 150 mm.
- The distance from the front of the rung to the surface in front of the access ladder (e.g. tower wall) must be at least 650 mm.
- If there are obstacles [1] in front of the access ladder, the clearance from the front of the rung must be at least 600 mm.

## Specifications for fixing onto the supporting structure

The surface under the anchoring points on the supporting structure must be capable of bearing the loads listed above.

Only approved anchor fittings may be used. This also applies to concrete supporting structures and masonry.

In the case of undefined substrata, the fixing system must be implemented in consultation with the structural engineer.

## Suitable types of attachment systems

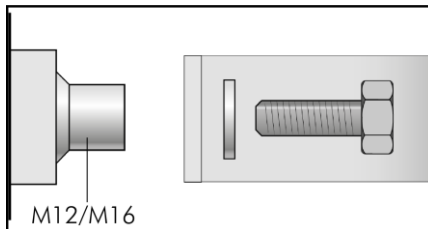

M12/M16 threaded bushes in steel structures

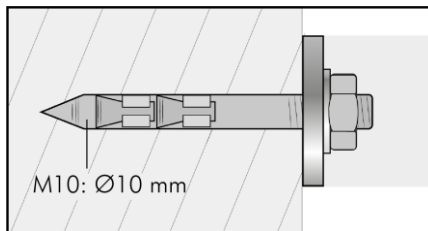

Anchor plug fastenings on concrete supporting structures with a concrete quality of at least C 20/25.



## NOTE

- Coordinate the fastening with the structural engineer.
- Observe the safety instructions of the anchor plug manufacturer.

## 5.2.5 General screw tightening torques (unless otherwise specified)

**Steel screws**  
**Strength class 8.8**

Screw sizes	Tightening torque
M8	17.9 Nm
M10	36.0 Nm
M12	61.0 Nm
M16	147.0 Nm
M20	297.0 Nm

**Steel screws**  
**Strength class 10.9**

Screw sizes	Tightening torque
M8	26.2 Nm
M10	53.0 Nm
M12	90.0 Nm
M16	216.0 Nm
M20	423.0 Nm

Max. tightening torques MA (Nm) with a total friction coefficient of  $\mu=0.08$  ( $\mu=0.08$  applies to a zinc-plated, non-oiled, dry surface).

**Stainless steel screws A2 and A4**  
**Strength class 70**

Screw sizes	Tightening torque
M8	14.5 Nm
M10	30.0 Nm
M12	50.0 Nm
M16	121.0 Nm
M20	244.0 Nm

Max. tightening torques MA (Nm) with a total friction coefficient of  $\mu=0.10$  ( $\mu=0.10$  applies to a non-oiled, dry surface).

Strength class 70 corresponds to cold-pressed treatment up to nominal lengths  $8 \times d$  and a yield strength utilisation of  $R_p 0.2 = 90\%$ .

## 5.3 Wall brackets

### **i** NOTE

#### Sequence of assembly steps

The sequence of the assembly steps may vary, depending on the specifications of the WTG manufacturer.

#### Wall bracket with rail clamp

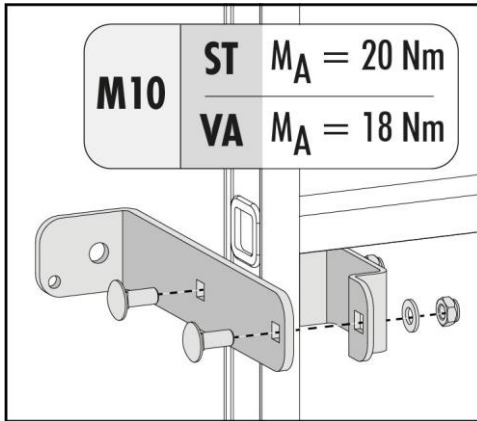

1. ▶ Bolt the wall brackets onto the supporting structure. As you do this, ensure that the rail clamps for the ladder mounting are pointed inward.
2. ▶ When all wall brackets are fastened, insert the access ladder between them.
3. ▶ Attach the rail clamps to the ladder and screw the ladder onto the wall brackets. Pay attention to the correct torques while doing so.

#### Wall bracket with U-bolt

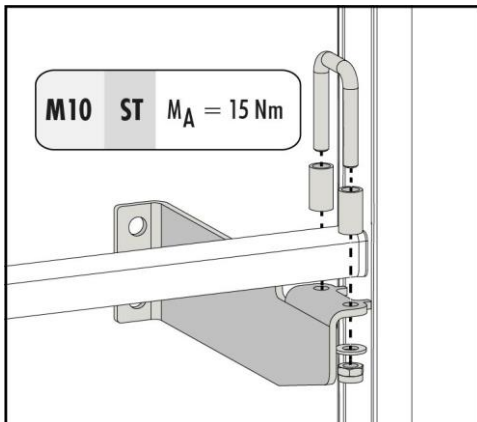

1. ▶ Bolt the wall brackets onto the supporting structure. Make sure the lugs of the wall bracket face inward.
2. ▶ When all wall brackets are fastened, insert the access ladder.
3. ▶ Guide the U-bolt through the sleeves and enclose the ladder rung with it. Tighten the screws on the lugs of the wall bracket to 15 Nm.

# Assembly

## Wall brackets with rung adapter

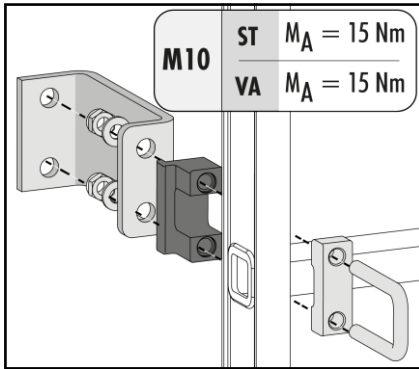

1. ► Bolt the wall brackets onto the supporting structure. When doing so, ensure that the shackles of the wall bracket are pointed outward.
2. ► When all wall brackets are fastened, insert the access ladder.
3. ► Place the rung adapter around the ladder rung and fix it to the wall bracket with the U-bolt. Pay attention to the correct torque while doing so.

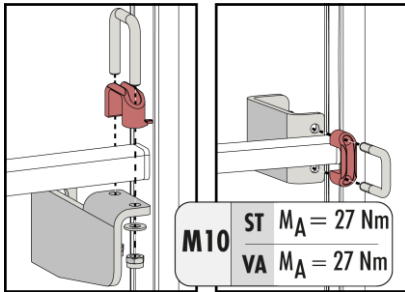

1. ► Bolt the wall brackets onto the supporting structure. Make sure the lugs of the wall bracket are face outward.
2. ► When all wall brackets are fastened, put in the access ladder.
3. ► Place the one-piece rung adapter horizontally or vertically around the rung and fix it to the wall bracket with the U-bolt. Pay attention to the correct torque while doing so.

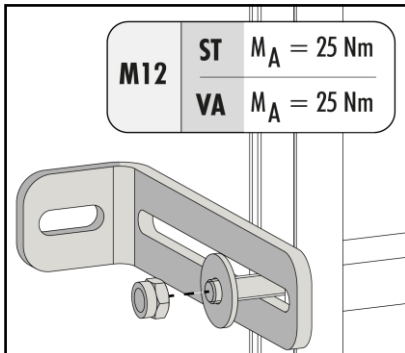

1. ► Bolt the wall brackets onto the supporting structure. When doing so, ensure that the shackles of the wall bracket are pointed outward.
2. ► When all wall brackets are fastened, insert the access ladder.
3. ► Guide the threaded rod through the rung and the elongated hole of the wall bracket. Insert a washer and screw the threaded rod tight. Pay attention to the correct torque while doing so.



## 5.4 Ladder connectors

### Aluminium inner rail connectors

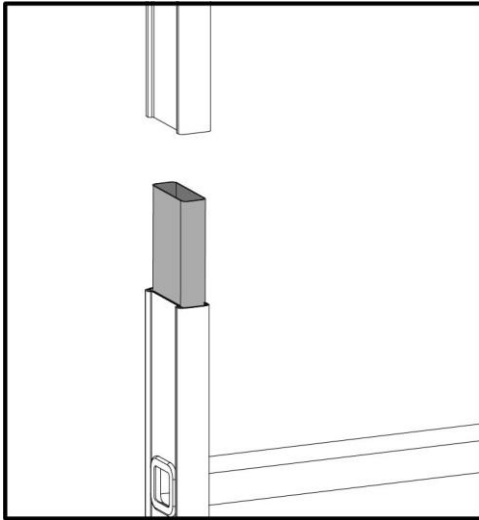

Can be used in 60 x 20 mm rail profiles. The installation depth of the connector is limited by the ladder rung. The rails are guided exactly over the surfaces of the inner rail connector.

1. ► Insert internal rail connectors up to the ladder rung in the ladder end.
2. ► Insert the ladder piece to be used until it reaches the stop on the inner rail connectors.



### ATTENTION!

#### Specifications for internal rail connectors

- An inner rail connector is to be used exclusively for guiding the ladder rail. After installation, a length of 30 mm should be visible, providing the rung spacing has been correctly observed.
- A rung spacing tolerance of  $\pm 15$  mm is only permitted in wind turbine generators (EN 50308). Hailo Wind Systems recommends a deviation in rung spacing of no more than  $\pm 2$  mm.
- The internal connectors must not be cut off!
- When using a ladder-guided service lift, a gap of up to 10 mm is permissible between the ends of the rails. However, the larger the gap, the more the lift guide rollers are subject to wear.
- HWS recommends a maximum rail gap of 5 mm to allow the service lift to run smoothly.

## Aluminium outer rail connector

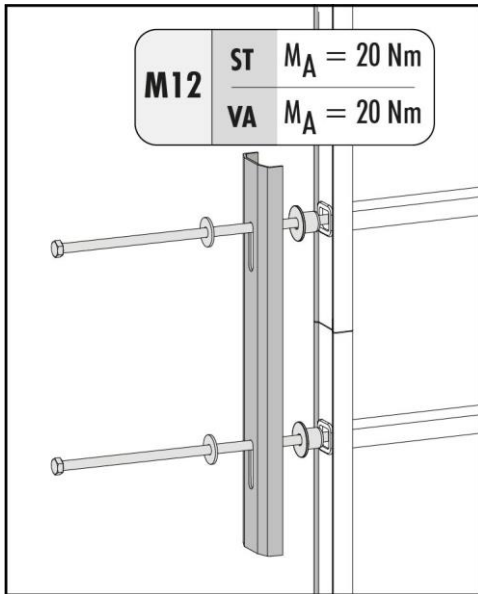

Threaded rod material: Stainless steel or galvanised steel

C-connector material: Aluminium

Available for 60 x 20 mm rail profiles

1. ► Insert threaded rods into the ladder rung and centre with centring sleeves at both ends.
2. ► Place the C-profiles on both rails and screw them tight. Pay attention to the correct torque while doing so.



### ATTENTION!

#### Distance between ladder rails

- There may be a distance of 30 mm between the ladder pieces, providing the specified rung spacing is observed.
- A rung spacing tolerance of  $\pm 15 \text{ mm}$  is only in permitted in wind turbine generators (EN 50308). Hailo Wind Systems recommends a deviation in rung spacing of no more than  $\pm 2 \text{ mm}$ .



### CAUTION!

#### Danger of cuts from sharp edges

- Always wear protective gloves!
- Properly deburr the cut edges (e.g. at the rail ends).

## External rail section connector

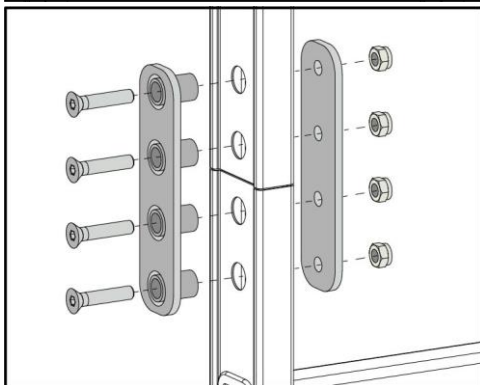
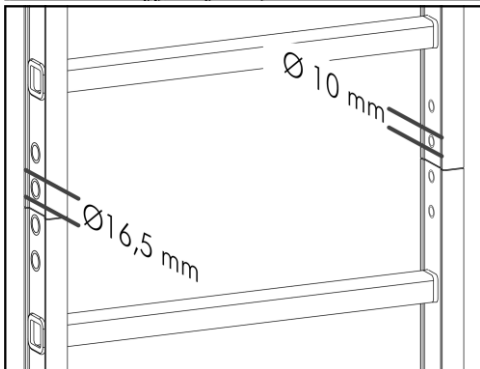
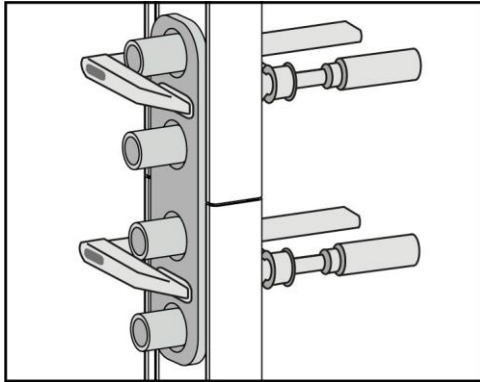

Material: Stainless steel

Can be used for 60 x 20 mm rail profiles.

The external rail section connector allows an intermediate ladder section to be installed or replaced at a later date, for example on a fixed ladder with ladder-guided service lift.

1. ► Place the ladder ends flush with each other at the rails.
2. ► Position the plate with screw sleeves vertically and horizontally centrally to the ladder rails and fix it with 2 screw clamps.
3. ► Using a 10 mm bit, drill 4 holes through the sleeves and the ladder rail. Then release the screw clamps and remove the plate.
4. ► Drill out the holes on the outside of the ladder rail to Ø 16.5 mm.
5. ► Mount the external rail section connector. Insert the plate with screw sleeves from the outside into the holes on the ladder rail. Place the second plate on the inside of the ladder rail and screw the rail connector tight.

### **i** NOTE

#### **Risk of damage!**

- Always observe the dimensional specifications for installing an intermediate ladder section!

## Assembly aid

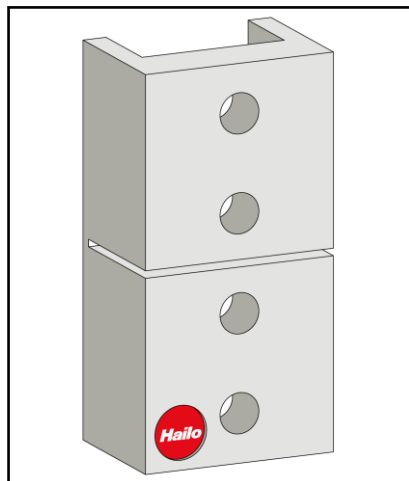

Material: Aluminium

Available for 60 x 20 mm rail profiles.

### **i** NOTE

Hailo Wind Systems recommends using the assembly aid when assembling the ladder.

It makes it easier to accurately cut and drill the components.

**The assembly aid can be ordered at [service@hailo-windsystems.com](mailto:service@hailo-windsystems.com).**

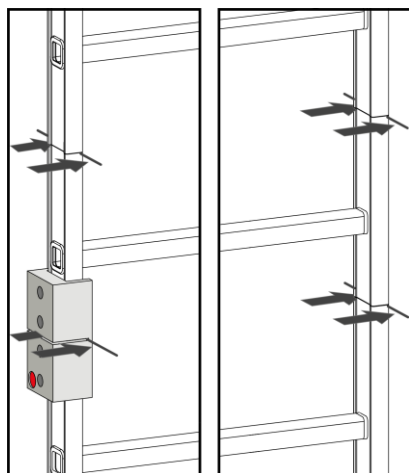

1. ► Place the assembly aid for cutting the ladder on the rail and fix it in place (with a screw clamp if necessary).
2. ► Saw a straight cut (90°) through the ladder on the saw guide.
3. ► Repeat this 3 times (see drawing).
4. ► Remove the sawn ladder piece and insert a newly cut ladder piece.
5. ► Place the assembly aid on the rail and fix it in place (with a screw clamp if necessary).

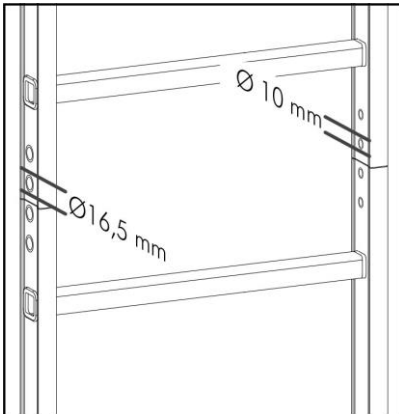
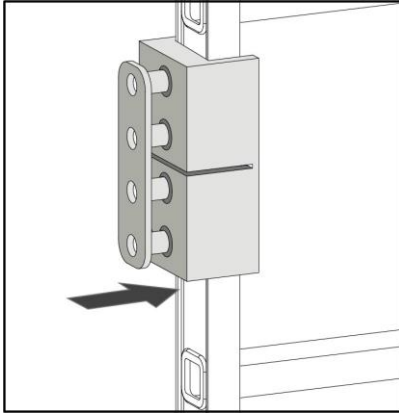

3. ► Insert the plate with screw sleeves into the assembly aid and use it as a drilling guide.
4. ► Using a 10 mm bit, drill 4 holes through the sleeves into the ladder rail.
5. ► Then remove the assembly aid.
6. ► Drill out the holes on the outside of the ladder rail to  $\text{Ø } 16.5 \text{ mm}$ .
7. ► Attach the ladder connection.

## Temperature-dependent assembly

### **(i) NOTE**

When assembling in high ambient temperatures or in regions with strongly fluctuating temperatures, HWS recommends keeping the rail gap as small as possible during installation so that it remains within the permissible range if temperatures drop sharply. When assembling in very low ambient temperatures, the rail gap should be bigger so that the ends of the rails do not push into each other if temperatures rise sharply, distorting the ladder. This recommendation may have to be implemented in a much restricted way when installing a rail-guided arrester system, due to the narrower tolerances for the gap dimensions.

## Putting in an intermediate ladder piece

### **i** NOTE

The intermediate ladder piece is used to connect ladder segments during ladder repairs or in the flange transition area of a wind turbine.

### **Assembly situation: Intermediate ladder piece in the flange transition**

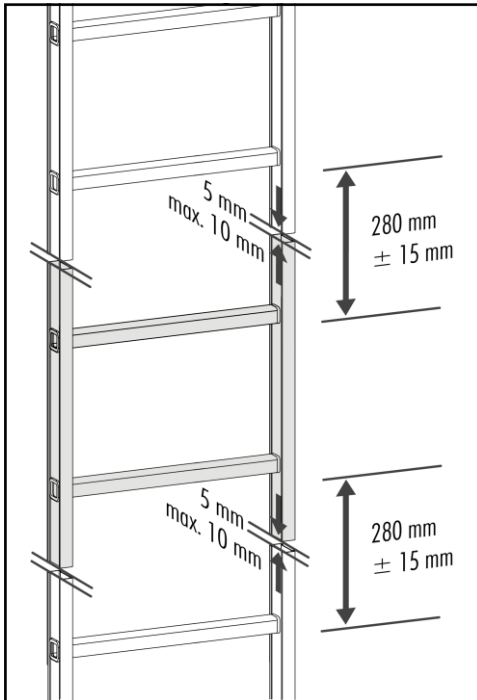

Preparation of the intermediate ladder piece for assembly on an existing access ladder in the flange transition area of a wind turbine generator.

1. ► Determine the spacing dimension of the ladder.
2. ► Saw the delivered intermediate ladder piece to the right size with a gap of no more than 10 mm at the top and bottom. Saw a cut at 90° to the ladder rail and then properly deburr the cut surfaces.
3. ► Using the external rail section connector or the external rail connector, mount the intermediate ladder piece on the access ladder.  
⇒ If possible, internal rail connectors, can also be used to connect the ladder elements together.

### **!** ATTENTION!

#### Specifications for the flange transition

When installing an intermediate ladder piece in the flange transition area of a wind turbine generator, a rung spacing tolerance of  $\pm 15$  mm is allowed.

## Assembly situation: Repair of a climbing route section

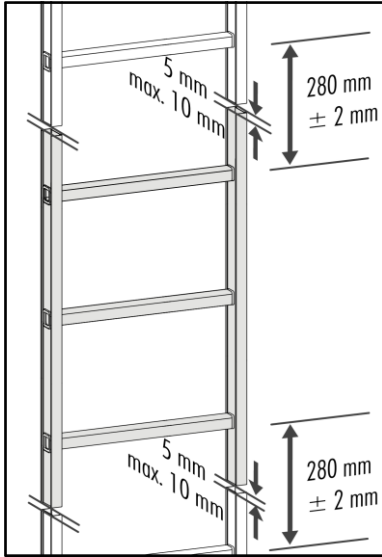

Preparation of the intermediate ladder piece for repair of an access ladder in the area of the climbing route.

A damaged section of the access ladder is replaced by a intermediate ladder piece.

1. ► Measure the damaged ladder section and saw it out with the cuts as close as possible to the mid-point between the ladder rungs. Perform the saw cut at a 90° angle to the ladder rail and afterwards deburr the cut surfaces.
2. ► With the aid of the external rail section connector or external rail connector, mount the intermediate ladder piece onto the access ladder.
  - ⇒ If possible, internal rail connectors, can also be used to connect the ladder elements together.



### ATTENTION!

#### Specifications for the intermediate ladder piece

When installing a intermediate ladder piece in a wind turbine generator, a rung spacing tolerance of  $\pm 15$  mm is allowed. Hailo Wind Systems recommends a deviation in rung spacing of no more than  $\pm 2$  mm.

- The length of the intermediate ladder piece is variable, but is at least two rung lengths. Please observe the maximum deviation between rails. This differs when using internal or external rail connectors.
- When using a ladder-guided service lift, a gap of up to 10 mm is permissible between the ends of the rails. However, the larger the gap, the more the lift guide rollers are subject to wear.
- HWS recommends a maximum rail gap of 5 mm to allow the service lift to run smoothly.

## 5.5 Rung repair kit

### Rung repair kit

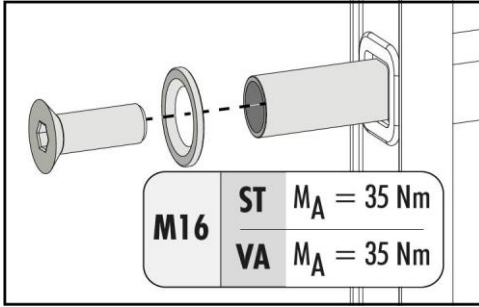

Material of insertion tube: Aluminium

Screw material: Galvanised steel

Use in the case of a repair.

1. ► Insert the insertion tube into the ladder rung.
2. ► Insert a washer on other ladder rails and screw on.

### Assembly aid for rung repair kit

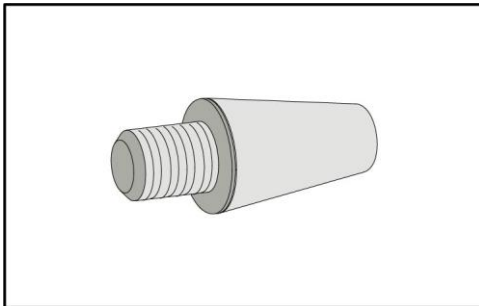

Use in the case of a repair where rungs are deformed.

1. ► Screw the assembly aid onto the insertion tube.
2. ► Fasten insertion tube on opposite side with screw.
3. ► Drive the insertion tube through the damaged rung with the assembly aid.
4. ► Unscrew the assembly aid.

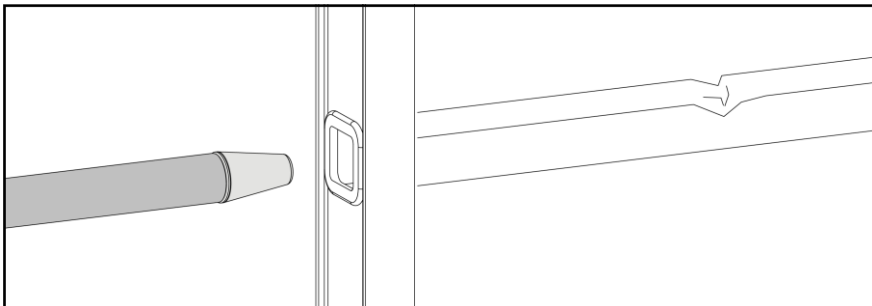



## 5.6 Base anchor

### Base fastening with rail clamp

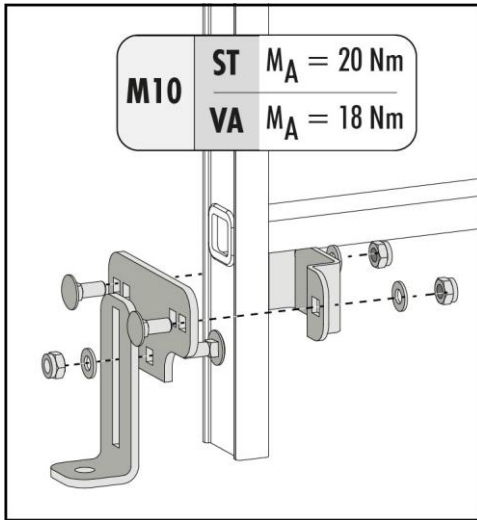

Material: Stainless steel or galvanised steel

Can be used in 60 x 20 rail profiles.

1. ► Place the rail clamp around the ladder rail and screw to the screw tab. Do this for both ladder rails.
2. ► Set the tab with the elongated hole on the floor and screw to the tab with the rail clamp.
3. ► Screw the tab with the elongated hole to the ground.

### Base fastening on ladder rung

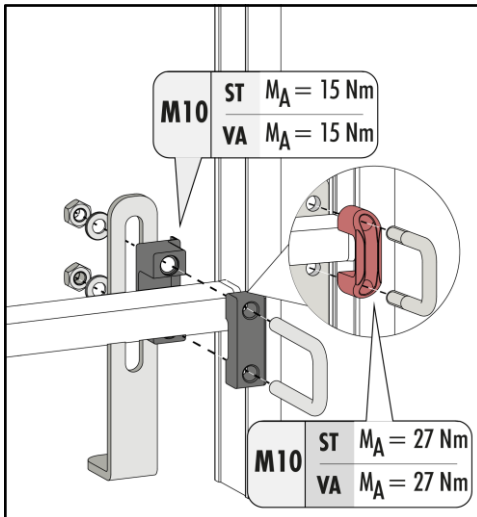

Material: Stainless steel or galvanised steel

For use with ladder-guided service lifts.

1. ► Place the rung adapter around the ladder rung and screw together on the tab with the elongated hole with the U-bolt.
2. ► Screw the tab with the elongated hole to the ground.
  - ⇒ Similarly, a one-piece rung adapter can be used.

## 5.7 Rest platforms



### ATTENTION!

#### Specifications for rest platforms

- In wind turbine generators there must be a rest platform every 9 m along the entire ladder as per DIN EN 50308.
- As per DIN EN ISO 14122-4: 2016, a rest platform must be installed every 12 m along the entire ladder length.

#### Rest platform on access ladder without fall protection rail

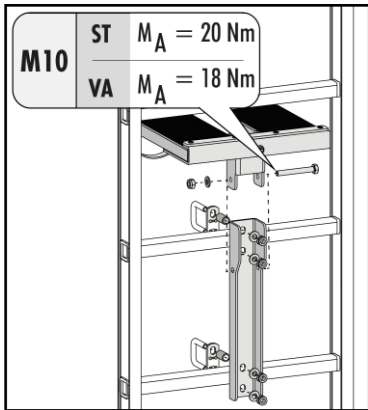

1. ▶ Mount the retaining rail centred on the rungs with 2 U-bolts.  
⇒ The rung is encircled by the U-bolt.
2. ▶ Screw the treading surface to the retaining rail of the rest platform.

#### Rest platform on access ladder with a fall protection rail with drilled holes

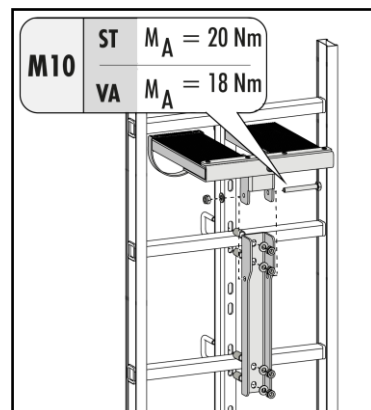

1. ▶ Mount the retaining rail centred on the rungs with 2 U-bolts.
2. ▶ Screw the spacer sleeves tight between the fall protection rail and retaining rail.  
⇒ The rung is encircled by the U-bolt.
3. ▶ Screw the treading surface to the retaining rail of the rest platform.



### NOTE

Tighten the M10 hex nut only as far that the rest platform can be swivelled smoothly.

## Rest platform on access ladders with a fall protection rail without drilled holes

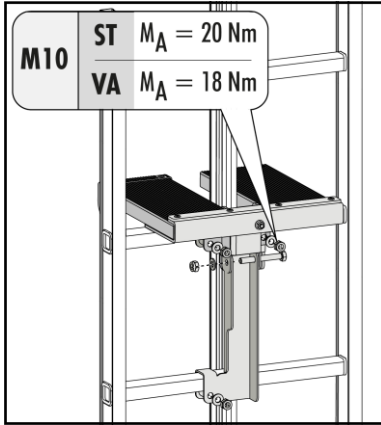

1. ► Place the retaining rail over the two rungs and fix in place with 3 screws.
2. ► Screw the treading surface to the retaining rail of the rest platform.

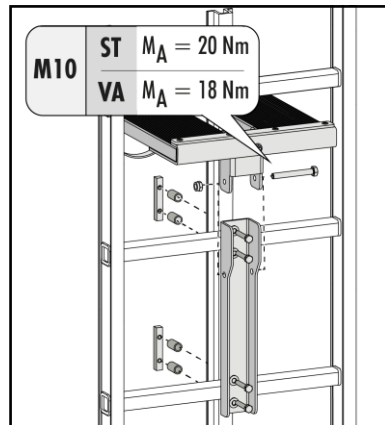

1. ► Lay the mounting block with thread in the groove of the fall protection rail.
2. ► Screw the screws through the spacer sleeves in the mounting block.
3. ► Screw the treading surface to the retaining rail of the rest platform.

### NOTE

- Tighten the M10 hex nut only as far that the rest platform can still be swivelled smoothly.
- This version of the rest platform can be used for various types of fall protection rails. For more information go to [info@hailo-windsystems.com](mailto:info@hailo-windsystems.com).
- Both types of rest platforms are mounted according to the same principle, as shown. However, the fastening components are not interchangeable.

## 5.8 Potential equalisation

Make sure the ladder is earthed along its entire length (equipotential bonding).

### Equipotential bonding using special conductive rung adapters

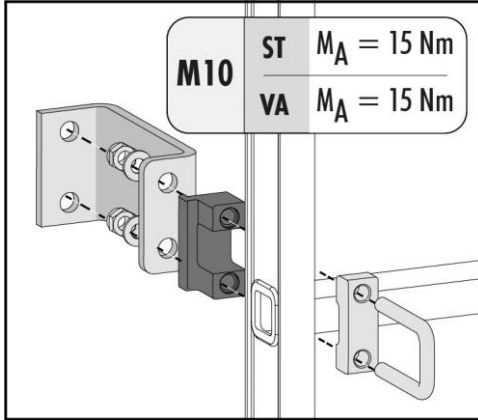

1. ► Screw the wall bracket to the screw tab. When doing so, ensure that the shackles of the wall bracket are pointed outward.
2. ► Place the rung adapter around the ladder rung and fix it to the wall bracket with the U-bolt. Pay attention to the correct torque while doing so.

⇒ The aluminium adapter part [1] ensures equipotential bonding.

### Equipotential bonding using one-piece rung adapter

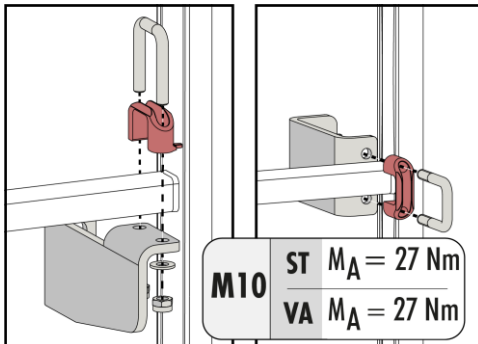

1. ► Place the one-piece rung adapter horizontally or vertically around the rung and fix it to the wall bracket with the U-bolt. Pay attention to the correct torque while doing so.

⇒ An additional component for equipotential bonding is not required when using the one-piece rung adapter.

⇒ The one-piece rung adapter ensures equipotential bonding.

## Equipotential bonding with bonding rail



### ATTENTION!

#### Avoid ladder buckling

Only insert connecting tabs together with internal rail connectors, as otherwise the ladder can buckle.

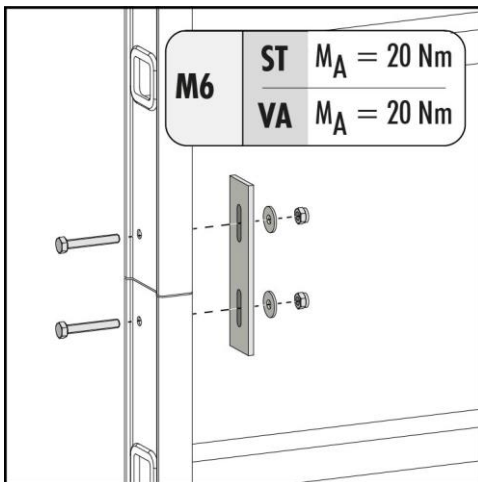
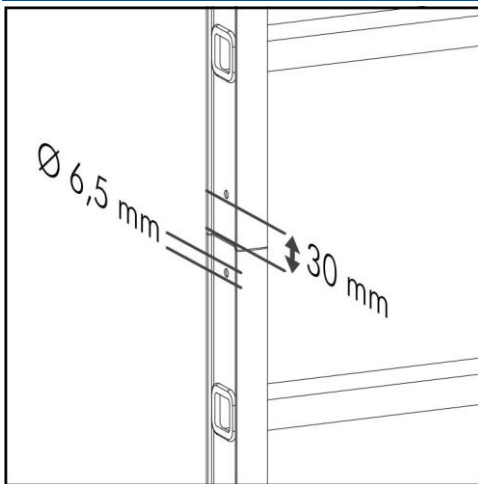

Bonding rail material: Aluminium

Screw material: Galvanised steel

1. ► Drill two holes ( $\varnothing 6.5 \text{ mm}$ ) into the ladder rails to be connected.
  - ⇒ When doing this, maintain a distance of 30 mm to each of the ladder ends.
2. ► Make sure that the ladder rails are connected to each other using internal rail connectors.
3. ► Bolt on the equipotential bonding rail with the screws provided.
  - ⇒ The ladder must be connected with the equipotential bonding rail along its entire length.
4. ► Finally, the ladder must be earthed at both ends on the supporting structure.

## 6 Usage

### 6.1 Daily inspection

Carry out a daily check before using the system.



#### **DANGER!**

**A damaged or poorly maintained system can lead to a fall, resulting in serious injury or death.**

Therefore:

- The access ladder system must be regularly inspected.
- Checked for any damage before and during use.
- If there are doubts about the safe condition of the system or any parts of it, they must be immediately taken out of use.
- This must be carried out by the manufacturer or another qualified person.
- In the event of a fall, the system must be inspected immediately by an authorised expert.

#### ***Fall protection***

Users are personally responsible for their own safety.

The personal fall protection equipment (PFPE) must be checked every working day to ensure that it is in perfect and safe condition.

Before and during use, the fall arrest system must be checked for any damage.

In addition to these installation instructions, the specifications in the arrester manufacturer's installation instructions be observed.

#### ***Permitted number of persons on the access ladder***

The number of persons permitted on each ladder may not exceed 10 persons. A minimum distance of 6 m must be maintained between each climbing person.

The minimum distance between persons must also be maintained in the event of an emergency or rescue.

### ***Use of fold-up rest platforms***

In addition, the specifications of the fall arrest system manufacturer must be observed, because the number of persons allowed may be less.

When using ladder-guided service lifts, make sure that the rest platforms are folded back in after use. Otherwise there is the danger of collision!

Check that the rest platforms can be folded easily.

### ***Unauthorised access***

The ladder must be protected from entry by unauthorised persons.



## **DANGER!**

**Disregarding the safety instructions may result in a fall and therefore lead to serious injury or death.**

Therefore:

- Always use your complete PFPE!
- Only connect to or release from the fall arrest system when in a secured position.
- Never transfer on or off unless secured to a suitable attachment point (see specifications of the WTG manufacturer). Connecting to the ladder rungs is prohibited!
- Only exiting the fall arrest system once secured to a suitable attachment point.
- When ascending or descending, you must be able to grasp the ladder firmly with both hands. This means that you may not be holding any heavy loads.
- When ascending or descending, do not touch or activate the fall arrester, which is also moving. This could impair or prevent the functioning of the brakes.

### 7 Inspection and maintenance

#### 7.1 Yearly inspection

At least once a year, the access ladder system must be checked for proper condition and functionality. This must be done by a knowledgeable and qualified person.

The check list for the yearly inspection of the access ladder system can be found in the appendix to these instructions.

The respective national regulations for operation and testing must be complied with.

#### 7.2 Maintenance and repairs

- All non-moving parts are maintenance-free.
- Rest platforms are easy to lubricate and check for ease of movement as required.
- Damaged surfaces must to be sealed with a suitable corrosion protection agent.
- Clean any dirt with a gentle cleaning agent.
- Do not use acids or alkalis.



#### **ATTENTION!**

#### **Observe all scheduled inspections and maintenance**

- It is the operating company's responsibility to ensure that scheduled inspections and maintenance are carried out.
- Proof of regular inspection is required for warranty claims.



## 8 Assembly log

### Assembly log for fixed access ladders DIN EN ISO 14122-4 / DIN EN 50308

General information			
Date of installation			
Location			
WTG no.			
Material	Aluminium		

Type of ladder	Length in metres		
Ladder with fall arrest system as per DIN EN 353-1:2018			
Ladder without fall arrest system as per DIN EN 353-1:2018			
Ladder with rear protection			

Ladder start	OK	Not OK	Comment
Correct entry dimension	<input type="checkbox"/>	<input type="checkbox"/>	DIN EN ISO 14122-4:100-400 mm

Wall brackets	OK	Not OK	Comment
Attachment to tower wall (dimension)	<input type="checkbox"/>	<input type="checkbox"/>	At least M12
Secure fit of screw connections (torque)	Nm		See manual or design drawing of WTG manufacturer
Threadlock used	YES <input type="checkbox"/>	NO <input type="checkbox"/>	
Distance to wall (see p. 28)	<input type="checkbox"/>	<input type="checkbox"/>	DIN EN ISO 14122-4 >200 mm from front of rung to wall behind ladder >650 mm from front of rung to wall in front of ladder

## Assembly log

Wall brackets	OK	Not OK	Comment		
Distance to tower flange (see p. 28)	<input type="checkbox"/>	<input type="checkbox"/>	DIN EN ISO 141222-4 > 150 mm from front of rung to wall behind ladder > 600 mm from front of rung to wall in front of ladder		
Vertical distance	2m <input type="checkbox"/>	>2m <input type="checkbox"/>	Manufacturer approval available	YES <input type="checkbox"/>	NO <input type="checkbox"/>
Correct installation according to specifications	<input type="checkbox"/>	<input type="checkbox"/>			

Ladder fastenings	OK	Not OK	Comment		
Correct installation	<input type="checkbox"/>	<input type="checkbox"/>	According to manufacturer specifications (see installation instructions or design drawing of WTG manufacturer)		
Secure fit of screw connections (torque)	Nm				

Rungs	OK	Not OK	Comment
Rung spacing $280 \pm 2$ mm; $\pm 15$ mm (flange)	<input type="checkbox"/>	<input type="checkbox"/>	For ladder ends / exchange pieces

Ladder connectors	OK	Not OK	Comment
<b>External rail section connector</b>	YES <input type="checkbox"/>	NO <input type="checkbox"/>	
Rail offset	<input type="checkbox"/>	<input type="checkbox"/>	max. 1 mm
Screw connection securely fitted	<input type="checkbox"/>	<input type="checkbox"/>	
Air gap at rail ends (max. 10 mm)	<input type="checkbox"/>	<input type="checkbox"/>	
<b>External rail connector</b>	YES <input type="checkbox"/>	NO <input type="checkbox"/>	
Screw connection securely fitted	<input type="checkbox"/>	<input type="checkbox"/>	
Air gap at rail ends (max. 30 mm)	<input type="checkbox"/>	<input type="checkbox"/>	
<b>Internal rail connector</b>	YES <input type="checkbox"/>	NO <input type="checkbox"/>	
Bolted joint (required for pylon)	<input type="checkbox"/>	<input type="checkbox"/>	

Ladder connectors	OK	Not OK	Comment
Gap between rail ends (max. 30 mm; max. 10 mm for ladder-guided service lifts)	<input type="checkbox"/>	<input type="checkbox"/>	

Rest platforms	OK	Not OK	Comment
Correct installation according to specifications	<input type="checkbox"/>	<input type="checkbox"/>	According to manufacturer specifications (see installation instructions or design drawing of WTG manufacturer)
Secure fit of screw connections (torque)	Nm		
Distance between rest platforms	m		

Marking	OK	Not OK	Comment
Nameplate attached	<input type="checkbox"/>	<input type="checkbox"/>	
Inspection tag attached	<input type="checkbox"/>	<input type="checkbox"/>	
Maintenance date entered	<input type="checkbox"/>	<input type="checkbox"/>	

Condition of the climbing path	YES	NO	Comment
Initial assembly	<input type="checkbox"/>	<input type="checkbox"/>	
Repair	<input type="checkbox"/>	<input type="checkbox"/>	
Usability	<input type="checkbox"/>	<input type="checkbox"/>	

Next inspection	Month:	Year:
Company performing services:		
Name of fitter (please print):		
Certificate number:		
Signature:		

## 9 Test report

**Recurrent inspection of fixed access ladders  
DIN EN 50308**

**DIN EN/ISO 14122-4 /**

General information				
Date of installation				
Location				
WTG no.				
Material	Aluminium			
Type of inspection	Recurrent inspection	<input type="checkbox"/>	Non-scheduled inspection	<input type="checkbox"/>

Type of ladder	Length in metres
Ladder with fall arrest system as per DIN EN 353-1:2018	
Ladder without fall arrest system as per DIN EN 353-1:2018	
Ladder with rear protection	

Marking	OK	Not OK	Comment
Present and legible	<input type="checkbox"/>	<input type="checkbox"/>	

Wall brackets	OK	Not OK	Comment
Screw connection securely fitted	<input type="checkbox"/>	<input type="checkbox"/>	
Deformation / damage	<input type="checkbox"/>	<input type="checkbox"/>	
Corrosion	<input type="checkbox"/>	<input type="checkbox"/>	

Ladder fastenings	OK	Not OK	Comment
Correct installation	<input type="checkbox"/>	<input type="checkbox"/>	
Corrosion	<input type="checkbox"/>	<input type="checkbox"/>	
Screw connection securely fitted	<input type="checkbox"/>	<input type="checkbox"/>	
Condition of fastening	<input type="checkbox"/>	<input type="checkbox"/>	

Rungs	OK	Not OK	Comment
Check rung fit (wiggle, shake, twist)	<input type="checkbox"/>	<input type="checkbox"/>	According to manufacturer's specifications
Rung bulge (outside rail)	<input type="checkbox"/>	<input type="checkbox"/>	When using a service lift on ladder
Deformation	> 1.5 mm <input type="checkbox"/>	> 1.5 mm <input type="checkbox"/>	
Non-slip surface	<input type="checkbox"/>	<input type="checkbox"/>	
Corrosion	<input type="checkbox"/>	<input type="checkbox"/>	
Cracks / ridges	<input type="checkbox"/>	<input type="checkbox"/>	
Rung spacing $280 \pm 2$ mm; $\pm 15$ mm (flange)	<input type="checkbox"/>	<input type="checkbox"/>	For ladder ends / exchange pieces
Secure fit of screw connections (repair kit)	<input type="checkbox"/>	<input type="checkbox"/>	If rung attached with repair kit

Rails	OK	Not OK	Comment
Deformation	> 1.5 mm <input type="checkbox"/>	> 1.5 mm <input type="checkbox"/>	
Cracks	<input type="checkbox"/>	<input type="checkbox"/>	
Ridges	<input type="checkbox"/>	<input type="checkbox"/>	
Corrosion	<input type="checkbox"/>	<input type="checkbox"/>	

Ladder connectors	OK	Not OK	Comment
<b>External rail section connector</b>	YES <input type="checkbox"/>	NO <input type="checkbox"/>	
Rail offset	< 1 mm <input type="checkbox"/>	> 1mm <input type="checkbox"/>	
Screw connection securely fitted	<input type="checkbox"/>	<input type="checkbox"/>	
Gap at rail ends (max. 10 mm)	<input type="checkbox"/>	<input type="checkbox"/>	
<b>External rail connector</b>	YES <input type="checkbox"/>	NO <input type="checkbox"/>	

## Test report

Ladder connectors	OK	Not OK	Comment
Screw connection securely fitted	<input type="checkbox"/>	<input type="checkbox"/>	
Gap at rail ends (max. 30 mm)	<input type="checkbox"/>	<input type="checkbox"/>	
<b>Internal rail connector</b>	YES <input type="checkbox"/>	NO <input type="checkbox"/>	
Bolted joint (required for pylon)	<input type="checkbox"/>	<input type="checkbox"/>	
Gap between rail ends (max. 30 mm; max. 10 mm for ladder-guided service lifts)	<input type="checkbox"/>	<input type="checkbox"/>	

Rest platforms	OK	Not OK	Comment
Fastener	<input type="checkbox"/>	<input type="checkbox"/>	
Function	<input type="checkbox"/>	<input type="checkbox"/>	
Corrosion	<input type="checkbox"/>	<input type="checkbox"/>	
Damage	<input type="checkbox"/>	<input type="checkbox"/>	

Result of inspection	OK	Not OK	Comment
Condition of the ladder	<input type="checkbox"/>	<input type="checkbox"/>	
Usability	<input type="checkbox"/>	<input type="checkbox"/>	
Repair/replacement	YES <input type="checkbox"/>	NO <input type="checkbox"/>	
Use not permitted	YES <input type="checkbox"/>	NO <input type="checkbox"/>	
Further testing necessary	YES <input type="checkbox"/>	NO <input type="checkbox"/>	

Next inspection	Month:	Year:
Company performing services:		
Name of fitter (please print):		
Certificate number:		
Signature:		

Comments

**Hailo Wind Systems GmbH & Co. KG**

Kalteiche-Ring 18 • D-35708 Haiger, Germany

Phone +49 2773 82-1410 • Fax: +49 2773 82-1561

E-mail: [info@hailo-windsystems.com](mailto:info@hailo-windsystems.com) • [www.hailo-windsystems.com](http://www.hailo-windsystems.com)