

Guided type fall arrester including a rigid anchor line - H-50.2 System

*H-50.2 rigid anchor line
System components*

DIN EN 353 -1: 2018
AS/ NZS 1891.3:1997
ANSI Z359.16-2016

Information booklet about

- *Assembly*
- *Using*
- *Inspection*

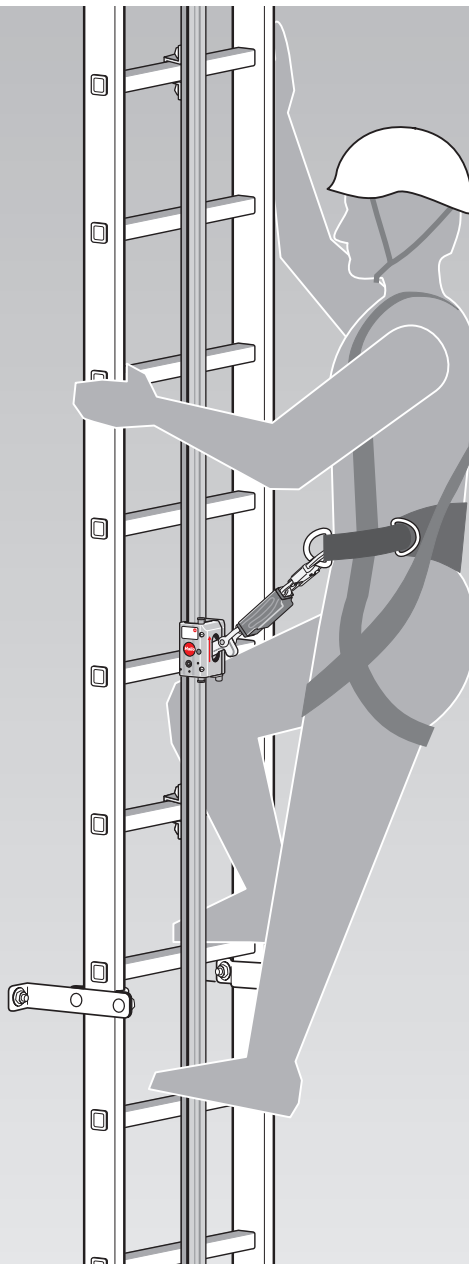

Introduction

Dear customer,

In purchasing the H-50.2 fall arrest system, you have opted for a quality product from the Hailo Wind Systems company.

We thank you for your trust in us.

This information booklet describes the assembly, use, maintenance and checks for the H-50.2 fall arrest system. Please read this booklet through in full and respect all the safety advice before beginning to assemble and use the H-50.2 fall arrest system.

In the event of damage arising due to a failure to respect the details in this information booklet and the safety instructions, the warranty lapses. We accept no liability for consequential losses arising from this.

The H-50.2 fall arrest system satisfies the requirements of the applicable European Regulation (EU) 2016/425 on Personal Protective Equipment for fall protection.

EU Type Testing was carried out at
Dekra Testing and Certification GmbH, Dinnendahlstraße 9, 44809 Bochum, Germany, "reference number: 0158".

Australian/New Zealand certificate was carried out at
SAI Global, Level 37, 680 George Street, Sydney NSW 2000, Australia.

The testing for the United States of America according to ANSI was carried out by
INTERTEK, 3933 US Route 11, Cortland, New York.

If you have any other questions or comments about our H-50.2 fall arrest system, please don't hesitate to call us.

We'd be delighted to assist.

Hailo Wind Systems GmbH & Co. KG
Kalteiche-Ring 18, 35708 Haiger, Germany

Tel. +49 (0) 2773 82-1410

info@hailo-windsystems.com
www.hailo-windsystems.com

EMERGENCY TELEPHONE NUMBERS:

We recommend that all users add the emergency telephone numbers listed below as contacts on their mobile phones.

Emergency services:

.....

Fire service:

.....

Plant operator:

.....

Hailo Service Hotline:

.....

Other important phone numbers:

.....

.....

.....

.....

Table of contents:

Introduction 2

1. *Initial Notes* 4

2. *Declaration of Conformity* 7

3. *EU-Type Examination Certificate* 8

4. *System Details* 10

5. *Safety Instructions* 12

6. *Performance Data* 18

7. *Standards and Regulations* 19

8. *Overview of System Components* 20

9. *Advice on Assembly* 22

10. *Assembly of Fall Arrest Rails* 26

11. *Use of H-50.2 Fall Arrest System* 36

12. *Markings and Notices* 38

13. *Rescue Measures* 40

14. *Assembly Log H-50.2 Fall Arrest System* 42

15. *Inspection H-50.2 Fall Arrest System* 44

16. *Inspection Plan H-50.2 Fall Arrest System* 46

17. *Documentation of the Inspection H-50.2 Fall Arrest System* 50

1. Initial Notes

In this information booklet and all relevant documents,
the term "Guided type fall arrester including a rigid anchor line" and the term "rigid anchor line"
as used in DIN EN 353-1:2018
are replaced by "fall arrest system" and "fall arrest rail"
for a better understanding of the user.

Texts or drawings tagged with these symbols flag up content and dangers that are of particularly importance. Failure to comply with these instructions may result in injury or loss of life.

Symbols used in this information booklet:



General warning advice



Risk of fatal injury in the event of a fall.



General instructions



See documentation



Use Personal Protective Equipment (PPE) against falls from a height



Additional advice



This information booklet must be read carefully and the contents noted before installing or using the H-50.2 fall arrest system.

The operator must ensure that this information booklet is available on site for every H-50.2 fall arrest system (or kept in a suitable location) and if required can be made available to the user at all times.

- On tall buildings or for deep shaft facilities, fall arrest systems are a mandatory requirement above a fall height ≥ 5 m (per DIN 18799-1) or ≥ 3 m (per EN ISO 14122-4).
- The H-50.2 fall arrest system is designed as a fall safety when using rung ladders and pole climbers, both above ground and below ground.
- A fall arrest rail is installed to the vertical ladders or pole climbers that are fixed to the structure in the centre of the vertical ladder or pole climber, which serves as a secure guide.
- The Hailo PARTNER H-50.2 fall arrester which runs along the rails is equipped with a shock absorber and is connected to the user's safety harness.
- The fall arrester is only licensed for protecting the user. Problem-free threading into the profiled rails, selflocking in the event of a fall, and its easy-glide action along the profiled rails – without obstructing the user as it moves – all guarantee safe climbs and descents.



The Hailo H-50.2 fall arrest system may only be used with a Hailo PARTNER H-50.2 fall arrester.

Therefore, before installing the H-50.2 fall arrest system, it is necessary to provide the respective user with a Hailo PARTNER H-50.2 fall arrester.

The number of fall arresters required depends on the number of personnel who will be using the fall arrest system.

Hailo PARTNER H-50.2 fall arrester

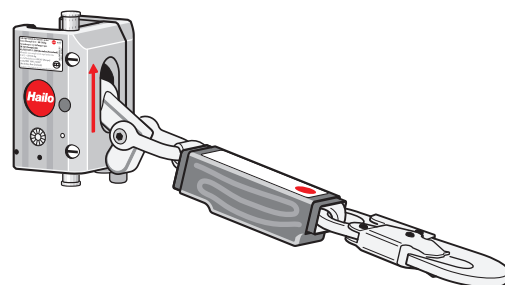

1. Initial Notes



The use, cleaning and storage of the fall arrester must only be in accordance with the specifications set out in the information booklet
Hailo PARTNER H-50.2 fall arrester with integrated BFD-50-136 shock absorber.



Should the equipment be sold on to another country, then for user safety it is necessary that this information booklet be available to him in the respective language of his country.



The specifications for the safe use of the Hailo H-50.2 fall arrest system with a Hailo PARTNER H-50.2 fall arrester (see page 15) must be respected absolutely.

The fall arrest system H-50.2 must not be used at different values.

Warning: Failure to comply with these requirements will lead to a risk of fatal injury in the event of a fall.

This information booklet is also available in the current official language of the destination country.

For more information, please visit
info@hailo-windsystems.com

or contact:

Hailo Wind Systems GmbH & Co. KG
Kalteiche-Ring 18
35708 Haiger, Germany

2. Declaration of Conformity

EC Declaration of Conformity

The manufacturer or his authorised representative established within the company:

Hailo Wind Systems GmbH & Co. KG
Kalteiche-Ring 18, 35708 Haiger, Germany

hereby declares in sole responsibility, that the guided type fall arrester including a rigid anchor line "H-50.2 System" described in the following pages complies with the provisions of the relevant Community harmonisation legislation of Regulation (EU) 2016/425 as well as the harmonised standard EN 353-1:2014 + A1:2017 (DIN EN 353-1:2018), the regulations of AS/NZS 1891.3:1997 and ANSI Z359.16-2016.

The notified body

Dekra Testing and Certification GmbH- testing laboratory for component safety,
Dinnendahlstraße 9, D - 44809 Bochum, identification no. 0158

has carried out the EU type examination in accordance with "Module B" and issued the
EC-Type Examination Certificate No. ZP/B036/21.

The PPE is subject to the conformity assessment procedure in accordance with „Module C2“
(Declaration of Conformity to type based on internal production control plus supervised product checks at random intervals)
under the supervision of the notified body Dekra Testing and Certification GmbH with the identification no. 0158.

AS/NZS 1891.3:1997

certified by

SAI Global, Level 37, 680 George Street, Sydney NSW 2000, Australia, SMK40750

ANSI Z359.16-2016

tested by

INTERTEK, 3933 US Route 11, Cortland, New York

Signed for and on behalf of Hailo Wind Systems GmbH & Co. KG

Haiger, 19.07.2021

Place, Date

Signature of authorized person (Johannes Weg, executive director)

3. EU-Type Examination Certificate



TRANSLATION

(1) EU-Type Examination Certificate

according to Module B Paragraph 6.1 of PPE Regulation (EU) 2016/425

- (2) Regulation of the European Parliament and of the Council of 9 March 2016 relating to personal protective equipment (PPE) - Regulation (EU) 2016/425
- (3) No. of EU-Type Examination Certificate: **ZP/B036/21** replaces ZP/B195/18
- (4) Product: **Guided-type fall arrester including a rigid anchor line**
Type: **Hailo PARTNER H-50.2**
- (5) Manufacturer: **Hailo Wind Systems GmbH & Co. KG**
- (6) Address: **Kalteiche-Ring 18, 35708 Haiger, Germany**
- (7) Risk category: **III**
- (8) The design and construction of this personal protective equipment and any acceptable variation thereto are specified in the appendix to this EU type-examination certificate.
- (9) The certification body of DEKRA Testing and Certification GmbH, Notified Body No. 0158 according to Chapter V of Regulation (EU) 2016/425 of 9 March 2016, certifies that this personal protective equipment has been found to comply with the essential Health and Safety Requirements given in Annex II to the Regulation. The evaluation results are recorded in report PB 21-054. Other possibly applicable Union legislations applicable to the specified personal protective equipment have not been taken into account in this EU-type examination certificate.
- (10) The essential Health and Safety Requirements are assured in consideration of
DIN EN 353-1:2018
- (11) This EU type-examination certificate relates only to the design, examination and tests of the specified personal protective equipment in accordance to Regulation (EU) 2016/425. For category III personal protective equipment, this EU type-examination certificate may only be used in conjunction with one of the conformity assessment procedures referred to Article 19 (c).
- (12) When applying the CE Marking according to Article 16 and 17 of Regulation (EU) 2016/425 to the products that conform to the types examined, the client is obliged to add, in accordance with the attached pattern, the identification number of the Notified Body engaged in the conformity assessment according to Module C2 or D. Furthermore, the manufacturer is obliged to issue an EU declaration of conformity in accordance with Article 15 of Regulation (EU) 2016/425 and to enclose it with the personal protective equipment, or to indicate the Internet address in the manual and in the instructions in Annex II, point 1.4., at which the EU declaration of conformity can be accessed.
- (13) This EU-Type Examination Certificate is valid until 2023-09-13.

DEKRA Testing and Certification GmbH
Bochum, 2021-07-19

Signed: Kilisch
Managing director

We confirm the correctness of the translation from the German original. In the case of arbitration only the German wording shall be valid and binding.

Managing director



STANDARDSMARK LICENCE

SAI Global hereby grants:

Hailo Wind Systems GmbH & Co KG

Kalteiche-Ring 18, Haiger, Germany

StandardsMark Licence

Manufactured to:

AS/NZS 1891.3:1997 - Industrial fall-arrest systems and devices - Fall-arrest devices

"the StandardsMark Licensee" the right to use the STANDARDSMARK as shown below only in respect of the goods described and detailed in the Schedule which are produced by the Licensee or on behalf of the Licensee* and which comply with the appropriate Standard referred to above as from time to time amended. The Licence is granted subject to the rules governing the use of the STANDARDSMARK and the Terms and Conditions for certification and licence. The Licensee covenants to comply with all the Rules and Terms and Conditions.

Certificate No:SMK40750

Issued: 16 April 2018

Expires: 15 April 2023

Originally Certified: 16 April 2018

Current Certification: 16 April 2018

Nicole Grantham
General Manager SAI Global Certification Services



* For details of manufacture, refer to the licensee

The STANDARDSMARK is a registered certification trademark of SAI Global Pty Limited (A.C.N. 050 644 642) and is issued under licence by SAI Global Certification Services Pty Limited (ACN 108 716 669) ("SAI Global") 680 George Street, Sydney NSW 2000, GPO Box 5420 Sydney NSW 2001. This certificate remains the property of SAI Global and must be returned to SAI Global upon its request. Refer to www.saiglobal.com, for the list of product models.



SMK40750

AS/NZS 1891.3:1997

4. System Details

Manufacturer's information:

Hailo order number:

Site information: *(to be completed by the operator)*

Name (operator): Telephone:

Street: Fax:

Postcode, town: E-Mail:

Date of commissioning:

Date

Signature of Operator

System information: (to be completed by the Assembly Manager)

Climbing unit:

Ladder system (Hailo)

Ladder system (customer-supplied)

Ladder design:

AL (Aluminium)

VA (Stainless steel)

ST (Steel-galvanized)

Other

Rail system type:

H-50.2 fall arrest rail (Aluminium)

Type of assembly

Centre of rung

Date

Signature of Assembly Manager

5. Safety Instructions



Information on system equipment, assembly and repairs



If the safety instructions on Pages 12 to 17 are not respected, then the manufacturer warranty lapses!

- The H-50.2 fall arrest system is tested and licensed as an overall system.
Combining this equipment with components from other manufacturers may result in failure of the overall system. The safe function of a part of the equipment or of the equipment in combination can be impaired, and there is a possible risk of falling or injury.
- Only system components from Hailo must be used for the H-50.2 fall arrest system. It is not permitted to use Hailo parts in conjunction with those of other manufacturers. Where the use of other manufacturers' components is unavoidable, this requires written authorisation from Hailo.
- The H-50.2 fall arrest system must only be used for the intended purpose. The use of this equipment for a purpose for which it is not intended is expressly forbidden, since this can lead to damage and thus to failure of the fall arrest system in the event of a fall.
- Before assembling the fall arrest system, all the parts must first be inspected to ensure they are in sound condition. If any damage has occurred to the system components in transport – e.g. if the fall arrest rail is bent – the component in question cannot be used.
- If a Hailo H-50.2 fall arrest system is retrofitted on an existing ladder facility or pole climbers of the standard EN ISO 14122-4, DIN 18799-1 or EN 14396, then in the event of any doubt (e.g. if the cross-section is smaller, if the stile-rung joint is not capable of bearing the load, if there is corrosion or poor anchorage to the building) safe use must be guaranteed – taking account of state-of-the-art engineering and/or by involving an engineering office to design and assess the provision.
It should be ascertained that the overall system is able to accommodate the dynamic load generated by a fall of 6 kN and a static load of 15 kN.
- If the necessary proofs (for safe accommodation of forces on the customer side) are not conducted, then in the event of an accident the ability to invoke the manufacturer's product liability is compromised. Liability then passes to the operator.
- Before each use, the necessary clear space in the working area below the user must be ensured, so that in the event of a fall no impact with the floor or other obstacle is possible. In addition, a safe distance of 3 m is to be maintained (see page 18).
- The protection afforded by the fall arrest system is invalidated if the user is in the bottom section of the rung ladder (see Page 18).
- Transport and storage:
All component parts of the system are to be secured in such a way that their function is not impaired and all components are to be kept in sound condition with respect to safety.
- The system or component parts of the system are to be replaced immediately if there is any doubt as to their safe condition. This must be carried out by the manufacturer or by other trained personnel.

- No modification or addition to the equipment should be undertaken without obtaining the express agreement of the manufacturer in writing beforehand.
- In the event of a fall, the action required under the emergency plan of the plant operator must be taken first.
- A system or component part of a system which has been subjected to stress as a result of a fall (e.g. the fall arrest rail H-50.2) is to be tested by trained personnel before further use and if necessary repaired or replaced.
- A fall arrester that has been subjected to stress as a result of a fall is not permitted for further use. In this case, the Hailo PARTNER H-50.2 fall arrester must be returned to the manufacturer for testing and/or repair.
- When using a combination of equipment parts (e.g. combining a user-specific safety harness with the fall arrester), it is absolutely essential that this does not result in any impairment of the overall system. In the event of a fall, any impairment can result in a failure of the fall arrest system.
- When a fall arrest system is retrofitted by the operator, the relevant standards need to be met (see page 19).
- The operator of the plant must ensure that metal conducting components are connected to equipotential bonding.
- When undertaking assembly, servicing or repair work, ensure that no scaffolding, platforms or any other items project into the potential fall area, thus constituting an additional danger in the event of a fall.
- The H-50.2 fall arrest system meets the highest safety requirements. It is tested and certified according to European and other international regulations. The use of climbing aids (either motor-driven or systems based on a counterbalance weight) may impair the safety and function of the H-50.2 fall

arrest system. Any operator and company who combine the two systems are responsible for ensuring that they are used solely in accordance with the regulations. A function test with subsequent declaration of non-objection – conducted and certified by an accredited test laboratory – is therefore essential.

The unrestricted safety and function of the H-50.2 fall arrest system in conjunction with the respective climbing aid must be assured and documented.

- Repairs may only be carried out by trained personnel and individuals authorised by the manufacturer. In addition, repairs must be carried out in compliance with the procedures specified by the manufacturer.
- During assembly and use of accessories for this system, the accompanying instructions must be respected accordingly.
- The user must follow the recommendations for use with other system components (see the Overview of System Components, Page 20/21).

5. Safety Instructions



Use of H-50.2 fall arrest system

- Before each use of the H-50.2 fall arrest system, a visual check of the system and the function of the Hailo Partner H-50.2 fall arrester must be carried out, employing the information booklet.
- Before using the fall arrest system with the fall arrester, the system needs to be inspected to ensure that it is in proper working order. It is not permitted to use the equipment where there are instructions regarding severe icing or contamination of the fall arrest system or where there is already severe icing or contamination.
- Contaminated or damaged equipment parts impair the function of the fall arrest system. In particular, the fall arrest rail must be kept in a clean and sound condition. Contact with oil, acid or other caustic liquids is to be avoided. It is not permitted to use a contaminated or damaged fall arrest system.
- The fall arrest system is designed for operation in temperatures ranging from $-40\text{ }^{\circ}\text{C}$ to $+60\text{ }^{\circ}\text{C}$.
- Extreme temperatures and weather conditions (e.g. heavy rain, snow and ice and temperatures of $< -40\text{ }^{\circ}\text{C}$ or $> +60\text{ }^{\circ}\text{C}$) may interfere with the functionality of the fall arrest system. The fall arrest system must not be used in these conditions.
- The accident prevention regulations BGV A1 and BG Rules BGR/GUV-R 198/199 (Germany) must be respected.
- The user of the fall arrest system should never be alone when using the system, as a second person should be available to call for immediate help in the event of an accident. It is strongly recommended that users always carry a mobile phone.
- The user of the fall arrest system must be physically and mentally capable of movement using the respective equipment. If he has been required to take medicines in advance of using the equipment, it is advisable to find out about possible side-effects which might result in impairment or physical injury if moving around using the equipment.
- In addition, users must investigate the local conditions beforehand in order to establish whether any specific areas at the site might constitute a hazard.
- The maximum number of personnel permitted to use a fall arrest system at the same time is 10 at a minimum distance of 6 m from each other..
The minimum distance between the persons may be disregarded in case of emergency or rescue.
- Prior to starting work, the user of the H-50.2 fall arrest system must seek information from the plant operator regarding an emergency plan as well as any rescue measures that might be necessary and how to initiate and execute them.



The contractor or operator of a plant must put in place a plan which covers all possible emergencies that might arise when using the fall arrest system and outlines the measures required for rescuing personnel.

Use of Personal Protective Equipment (PPE)

- When using the H-50.2 fall arrest system, it is absolutely essential to use the Hailo PARTNER H-50.2 fall arrester as Personal Protective Equipment (PPE).
- Before using the H-50.2 fall arrest system, follow the instructions in the information booklet for the fall arrester.
- The Hailo PARTNER H-50.2 fall arrester may only be used for climbing and descending using the H-50.2 fall arrest system. The use of this equipment for a purpose for which it is not intended is expressly forbidden, since this can lead to damage and thus failure of the fall arrester in the event of a fall.
- Personal protective equipment may only be used for the intended purpose and by such persons as have been instructed in its safe use and who possess the corresponding knowledge.
- The Personal Protective Equipment (PPE) should be in the personal possession of the respective person and only used by this user. Use by a more extended group of people is not to be considered advisable.
- Increased caution is required when using the H50.2 fall arrest system near moving machinery and electrical equipment.
- The Hailo PARTNER H-50.2 fall arrester may not be used for work positioning. If work positioning is required, a separate system must be used.
- The user must not touch or manipulate the fall arrester while climbing or descending. Such action may impair or even prevent the braking action of the equipment. For reasons of safety, the user is not permitted to grip or manipulate the fall arrester while climbing or descending, except when the user is in a position of safety and there is no risk of falling.
- In the event of a fall, the action required under the emergency plan of the plant operator must be taken first. When a system or component parts of a system (such as the H-50.2 fall arrest rail) have been subjected to stress as a result of a fall they are no longer approved for further use and must be inspected and repaired by an expert / authorised person before further use. Repairs to the fall arrester may only be carried out by the manufacturer.



For safe use of the Hailo PARTNER H-50.2 fall arrester at the H-50.2 fall arrest system the following guidelines must be observed:

- Hailo PARTNER H-50.2 fall arrester is approved for a total weight of 50 to 136 kg. (total weight = body weight of the user, including clothing and equipment)
- Max. deviation of fall arrest rail (Mat.: aluminium) to the vertical = -3° to $+15^{\circ}$

5. Safety Instructions



Use of Personal Protective Equipment (PPE)

- Only original Hailo parts may be used on the Hailo Partner H-50.2 fall arrester. Defective or worn parts may only be replaced by Hailo parts.
- Only safety harnesses which comply with EN 361 (for Europe), AS/NZS 1891.1:2007 (for Australia/New Zealand) and OSHA/ANSI (North America) are permitted for use with the Hailo PARTNER H-50.2 fall arrester on the H-50.2 fall arrest system. Please follow the instructions for use for the safety harnesses used.
- Connecting parts on the fall arrester must not be lengthened or shortened.
- Do not use any support harnesses, seat harnesses, elasticated harnesses or older Form B safety harnesses which only partially enclose the body. These harnesses should not be used when climbing.

Additional attaching elements:

(e.g. when leaving the H-50.2 fall arrest system):

- The lengths of the attaching elements for supplementary fall safety systems should be selected to be as short as possible, so that in the event of a fall the distance of the fall is correspondingly limited.
- Additional attaching elements, e.g. Y harnesses, should only be attached to the fastening-points provided for them (EN 795).
- The safety of the user of the fall arrest system depends on the effectiveness of the equipment!



The specifications for the safe use of the Hailo H-50.2 fall arrest system with a Hailo PARTNER H-50.2 fall arrester (see page 15) must be respected absolutely.

The fall arrest system H-50.2 must not be used at different values.

Warning: Failure to comply with these requirements will lead to a risk of fatal injury in the event of a fall.





The safety harness must sit firmly on the body and be correctly adjusted [A], [B].

It is forbidden to use the fall arrest system with a loose safety harness that has not been adjusted to provide a sufficiently tight fit [C], [D].

The spring hook on the shock absorber may only be attached to the authorised retaining eye on the safety harness [E].

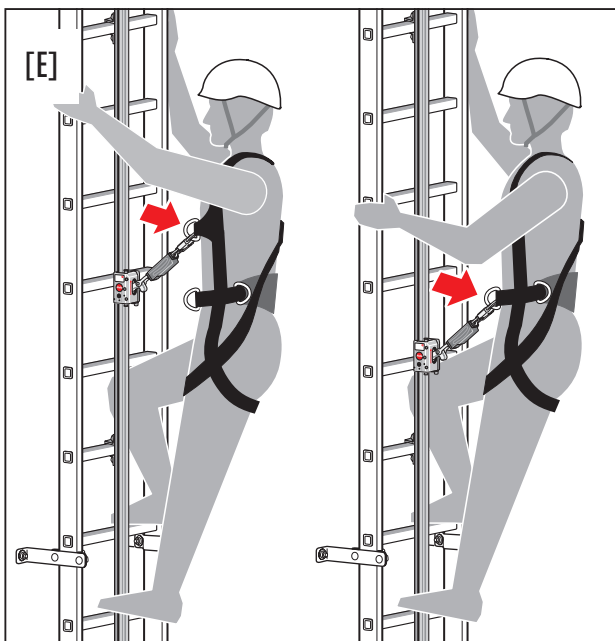
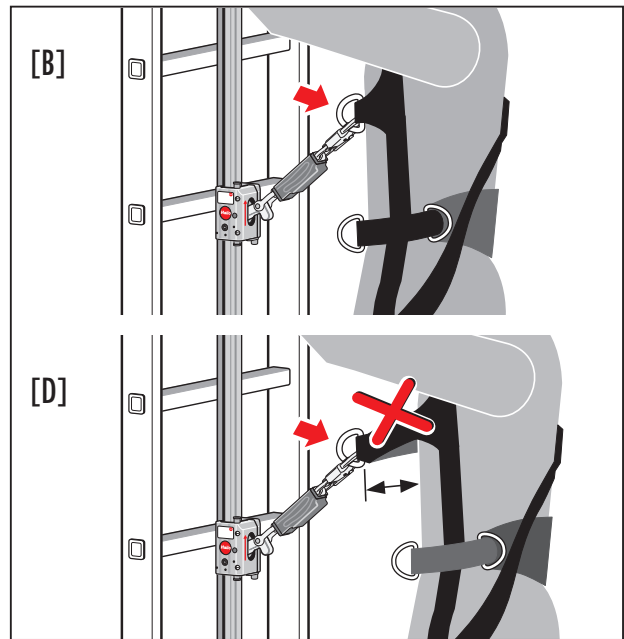
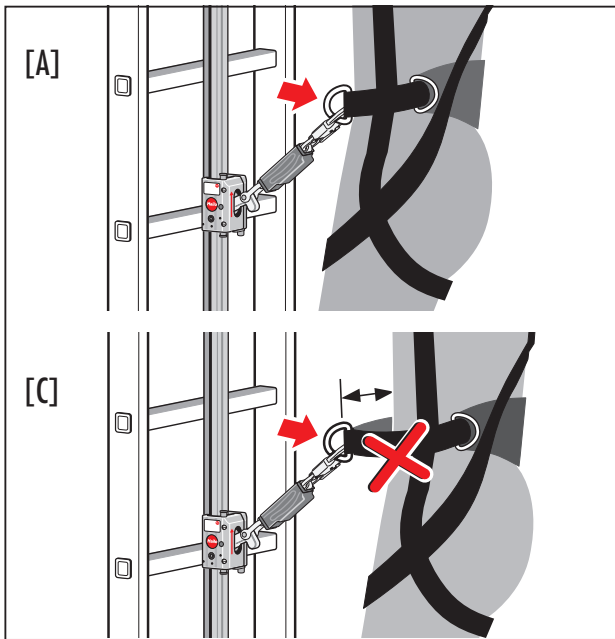
The fall arrester must not be connected to any retaining eyes to the sides of the safety harness that may be provided as an additional element in the hip area.





The user should basically avoid standing in a position on the fall arrest rail where they are directly above the fall arrester [F].

Warning "Risk of falling"!



6. Performance Data



For the H-50.2 fall arrest system, calculating the performance data and the necessary free space to arrest the person in the event of a fall indicates a safe distance of 3 m.

The Hailo Partner H-50.2 fall arrester on the H-50.2 fall arrest system does not provide protection when the user is on the lower section of the climbing unit (i.e. < 3 m from the top edge - access level).



The plant operator must install an appropriate warning notice (see Safe Distance Sticker) on the building to inform the user beyond all doubt of the safe distance.

The H-50.2 fall arrest system must be identified with a type plate at the point of access which indicates the type of fall arrester to be used with the H-50.2 fall arrest system.

When new types of fall arrester are used, the operator must ensure that this information is clearly visible to the user.

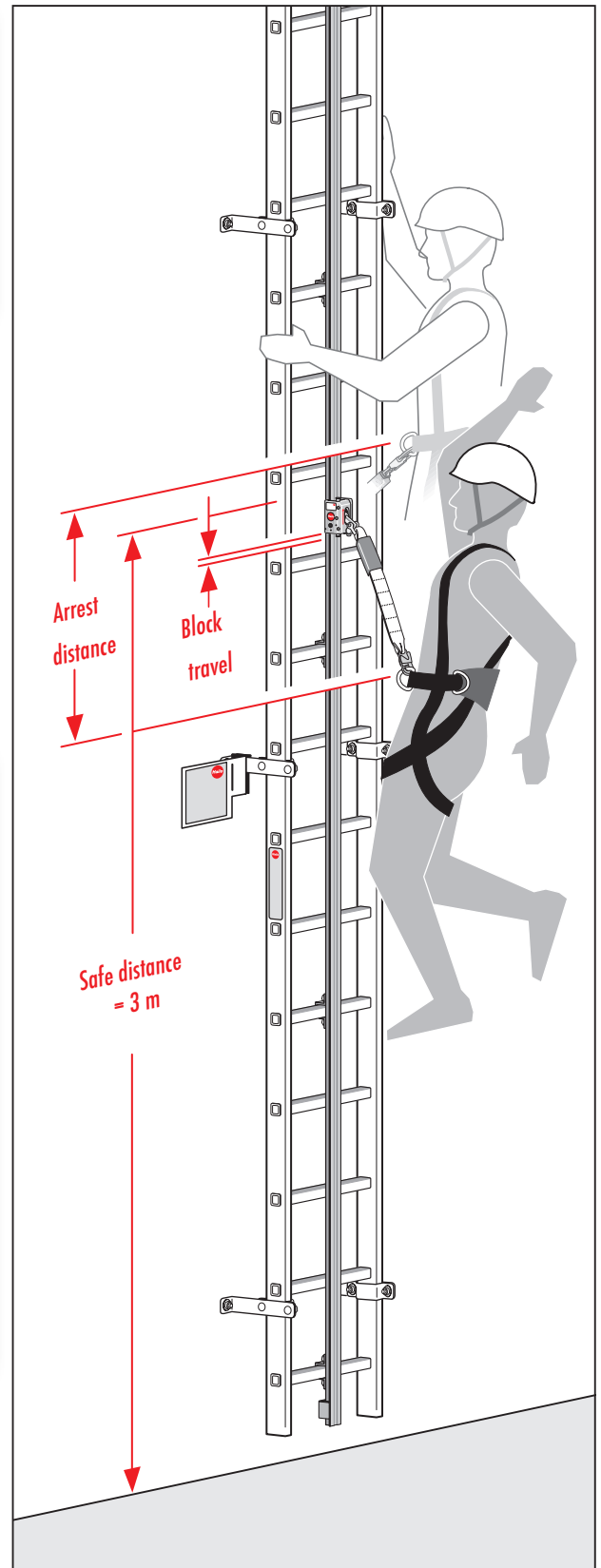

7. Standards and Regulations

AS/NZS 1891.1	Industrial fall-arrest systems and devices Part 1: Harnesses and ancillary equipment
AS/NZS 1891.3	Industrial fall-arrest systems and devices Part 3: Fall-arrest devices
ANSI Z359.16-2016	Safety Requirements for Climbing Ladder Fall Arrest Systems - part 16
(EU) 2016/425	Regulation on personal protective equipment
BetrSichV	Occupational health and safety legislation "Ordinance on safety and health protection in the supply of work equipment and its use in the workplace, safety in the operation of plant requiring monitoring and the organising of health and safety in operations"
BGV A1	Accident prevention regulations "Principles of prevention"
BGI 694	Guidelines for the use of ladders and steps
BGR/GUV-R 198	Ruling on the use of personal protective equipment to prevent falls
BGR/GUV-R 199	Ruling on the use of personal protective equipment for rescue at height or underground
EN 353-1	Personal protective equipment to prevent falls from height: Guided type fall arrester including rigid anchor line
EN 361	Personal protective equipment to prevent falls from height: Full body harnesses
EN ISO 14122-1	Safety of machinery – Permanent means of access to machinery – Part 1: Choice of fixed means of access between two levels
EN ISO 14122-4	Safety of machinery – Permanent means of access to machine plant – Part 4: Permanent vertical ladders
DIN 18799-1	Fixed ladders for construction work Part 1: Fixed ladders with uprights – safety requirements and tests
EN 795	Anchor devices
DIN CEN/TS 16415	Anchor devices: Recommendations for anchor devices for use by more than one person simultaneously
EN 50308	Wind turbines – labour safety

8. Overview of System Components

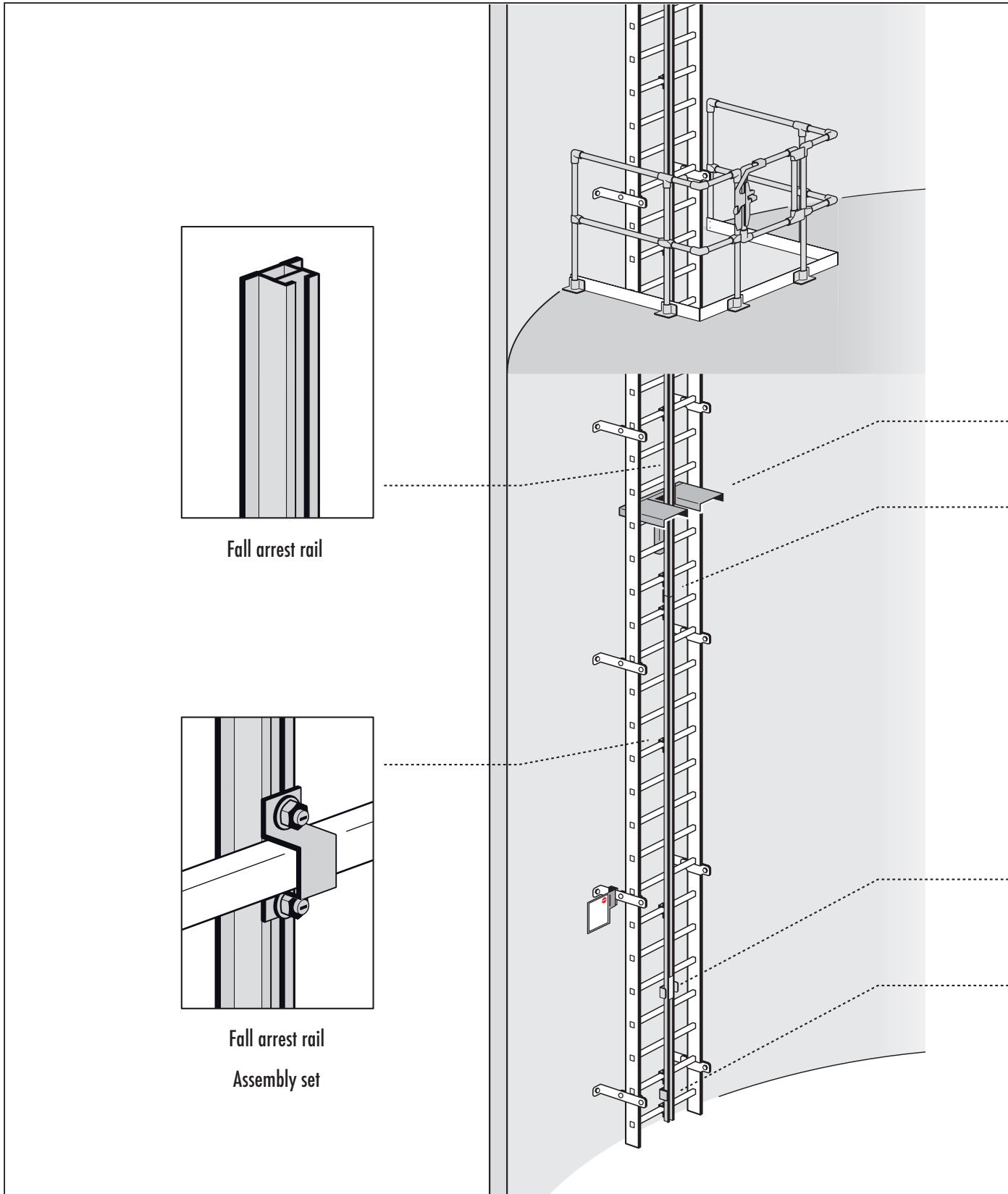

All the illustrations provided are examples and may differ from the version shown depending on the design.

For more information on the design and item number of the individual products, please visit: www.hailo-windsystems.com

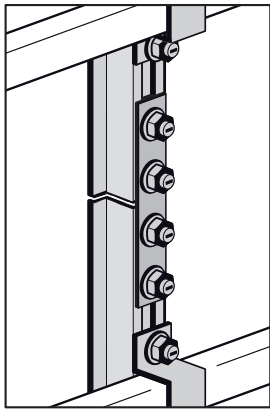

Rail connector

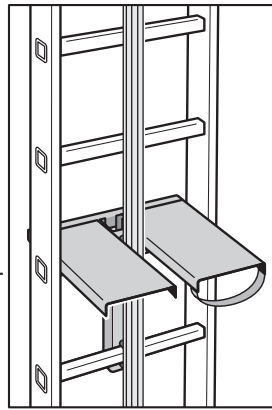

Folding rest platform

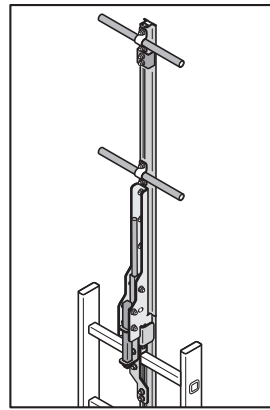

Insertable entrance aid

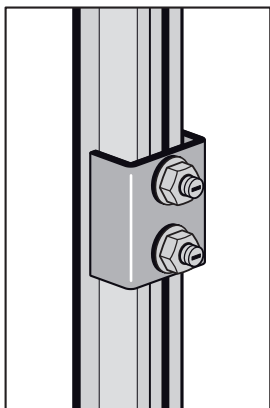

End-stop
above + below

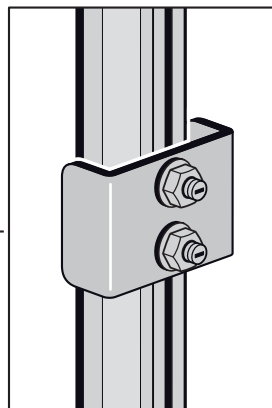

Optional: locking for
third-party devices

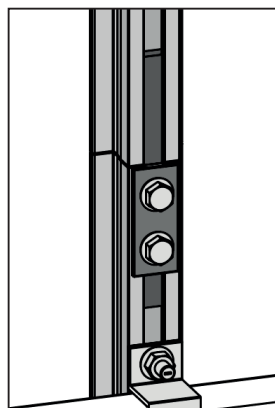

Variable
rail connector

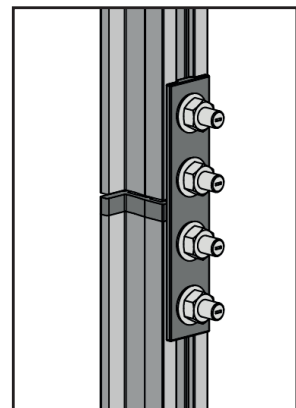

Compensational
rail connector

9. Advice on Assembly

Preliminary note

- Before commencing assembly, first ensure that the requisite loads can be accommodated by the structure.
- If documentation confirming this is not available, then a statics report taking account of the requisite load accommodation is a mandatory requirement and must be verified.
- If the required proof (that the customer's facilities can safely accommodate the requisite forces) is not available, then the manufacturer may refuse liability for the product in the event of a claim. Liability then passes to the operator.

Fitters

- At least two people are needed to assemble the fall arrest system.
- The fitters cannot be secured on the system to be installed.
- To secure the fitters, an approved fastening point pursuant to DIN EN 795 on the building or on some other construction element is to be used.

Information on fitting the system to concrete structures:

- Only dowels permitted under building regulations requirements may be used for concrete structures.
- When assembled on unspecified foundation material, the fastening system is to be implemented in consultation with the design engineer responsible for the supporting framework.
- Concrete requirement: Concrete of at least category C 20/25 is required.

Information on fitting system to masonry:

- Only dowels permitted under building regulations requirements may be used for masonry.
- When assembled on unspecified foundation material, the fastening system is to be implemented in consultation with the design engineer responsible for the supporting framework.
- It is also possible to anchor the system through the masonry using a counter plate. This should be discussed and verified with the structural engineer.



Before fitting the vertical ladder, ensure that the transfer of forces to the load-bearing structure is guaranteed with adequate safety (in consultation with the design engineer responsible for the supporting framework).

Follow the fitting instructions provided by the manufacturer of the dowels.

Screw tightening torques

- When using steel screws:

Max. tightening torques in (Nm) with a total coefficient of friction of $\mu = 0.08$ ($\mu = 0.08$ corresponds to a galvanised, unoiled, dry surface)

Property class 8.8:	Property class 10.9:
M 8 = 17,9 Nm	M 8 = 26,2 Nm
M 10 = 36,0 Nm	M 10 = 53,0 Nm
M 12 = 61,0 Nm	M 12 = 90,0 Nm
M 16 = 147,0 Nm	M 16 = 216,0 Nm
M 20 = 297,0 Nm	M 20 = 423,0 Nm

- When using A2 + A4 stainless steel screws:

Max. tightening torques in (Nm) with a total coefficient of friction of $\mu = 0.10$ ($\mu = 0.10$ corresponds to an unoiled, dry surface)

Property class 70:

M 8 = 14,5 Nm
M 10 = 30,0 Nm
M 12 = 50,0 Nm
M 16 = 121,0 Nm
M 20 = 244,0 Nm

Property class 70 corresponds to cold-press fabrication up to a nominal length of $8 \times d$ and a utilisation of the yield strength of $R_p 0.2 = 90\%$.

Carrying out assembly

- Only use absolutely clean and undamaged system parts. Particular attention is to be paid to ensuring undamaged running surfaces on the rails.
- Damaged parts must be replaced using new parts.
- The testing plan and test log for the H-50.2 fall arrest system are found on Pages 46-53.
- The assembly log for the H-50.2 fall arrest system is found on Pages 42/43.

Assembly log

- Assembly of the H-50.2 fall arrest system is to be documented by the assembly manager for the assembly firm in full, permanently, and legibly in the assembly log.



Warning "Risk of falling"!

During assembly, use a fall arrest system complying with the specifications of EN 363

9. Advice on Assembly

Assembly on rung ladder (Measurement specifications)

The H-50.2 fall arrest system is designed for fitting to Hailo vertical ladders. It can however also be fitted to ladder systems (i.e. the equivalent ladders supplied by other manufacturers) that conform to the relevant standards and regulations (see page 19).

When fitting H-50.2 fall arrest rails to ladders supplied by other manufacturers, it is essential to comply with the information on page 28 (distance between fastenings).

Fig. A) The following applies for the distance [A]:

EN ISO 14122-4: [A] =

The distance between the surface where the user commences climbing and the first rung must not exceed the distance between the first two rungs of the ladder

DIN 18799-1: [A] =

distance between rungs [B] + 100 mm,
min. 1/2 distance between rungs [B]

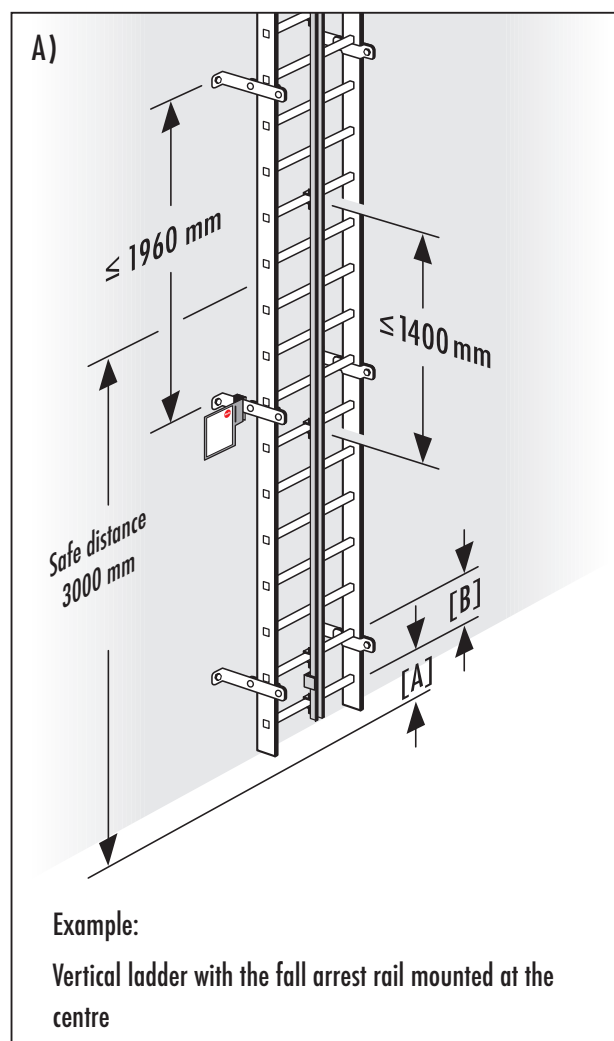

Information on fastening the system to the structure:

- The anchor points and their connections (i.e. brackets and means of attachment) must be capable of accommodating the loads.
- When dimensioning the ladder brackets and the anchor points, make sure that they can withstand a dynamic load of 6 kN and a static load of 15 kN from the complete system.
- The anchor points may not exceed a vertical distance apart of 2000 mm. Effectively, this is 1960 mm with a rung distance of 280 mm (see Fig. B). Larger distances must be approved in advance by Hailo Wind Systems.
- The anchor points must always be arranged in pairs at the same level to the right and left of the ladder.
- The base layer on the structure for the anchor points must be suitable and sufficiently rated for the loads stated above.
- Suitable base layers:
Steel structures with threaded rings (min. M 12) or screw connections that pass through the structure, or where anchor dowels are used to attach the system to concrete structures of a min. category C 20/25 concrete, using only anchor dowels permitted under building regulations (see Fig. C).
- Masonry is not suitable as a base layer for attaching the system using anchor dowels. In such cases, it is possible to anchor the system through the masonry using a counter plate. However, it is essential that this is designed with a construction engineering agency and verified accordingly by them.

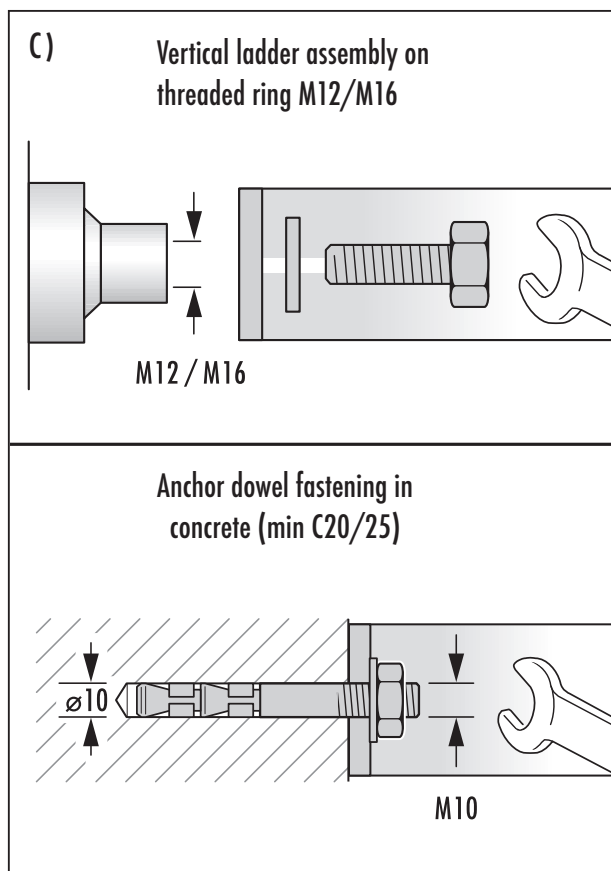
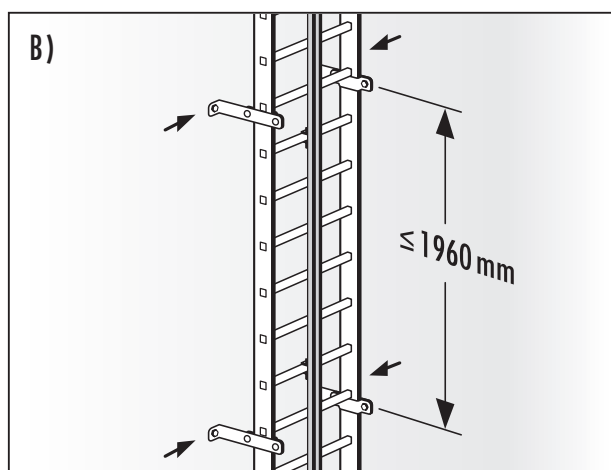

10. Assembly of Fall Arrest Rails

10.1 Assembly on vertical ladders (Examples)

Assembly on rungs (at centre)

Examples: Structural engineering

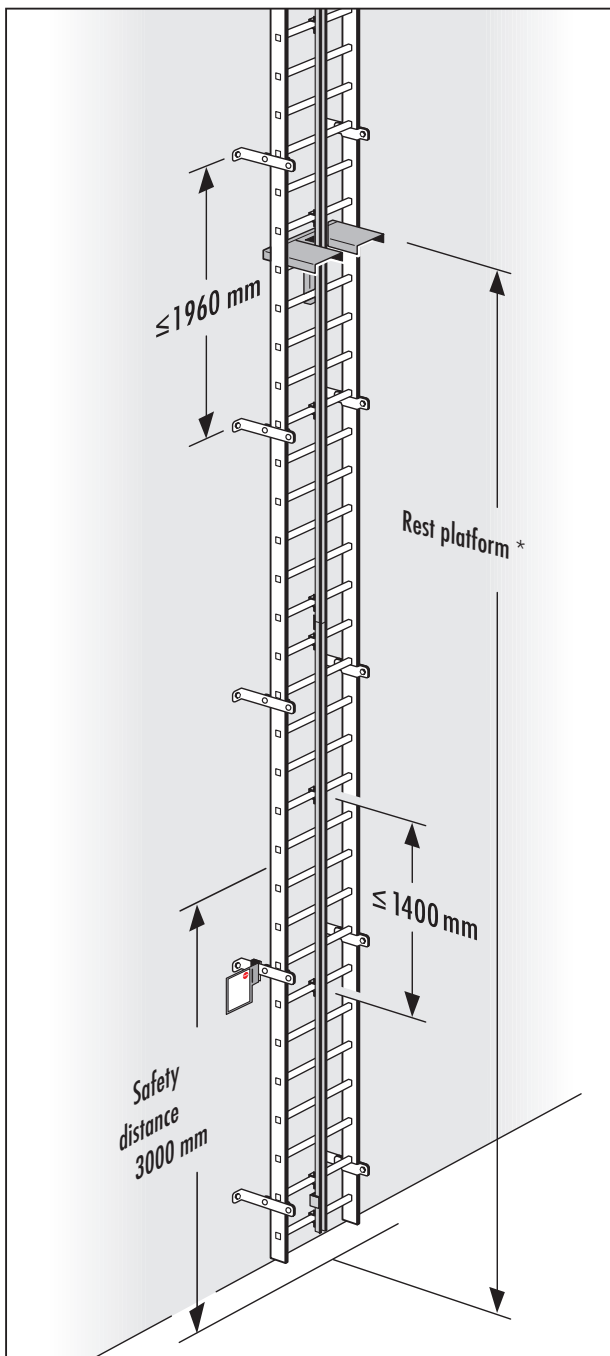

Assembly on rungs (at centre)

Examples: Wind turbines

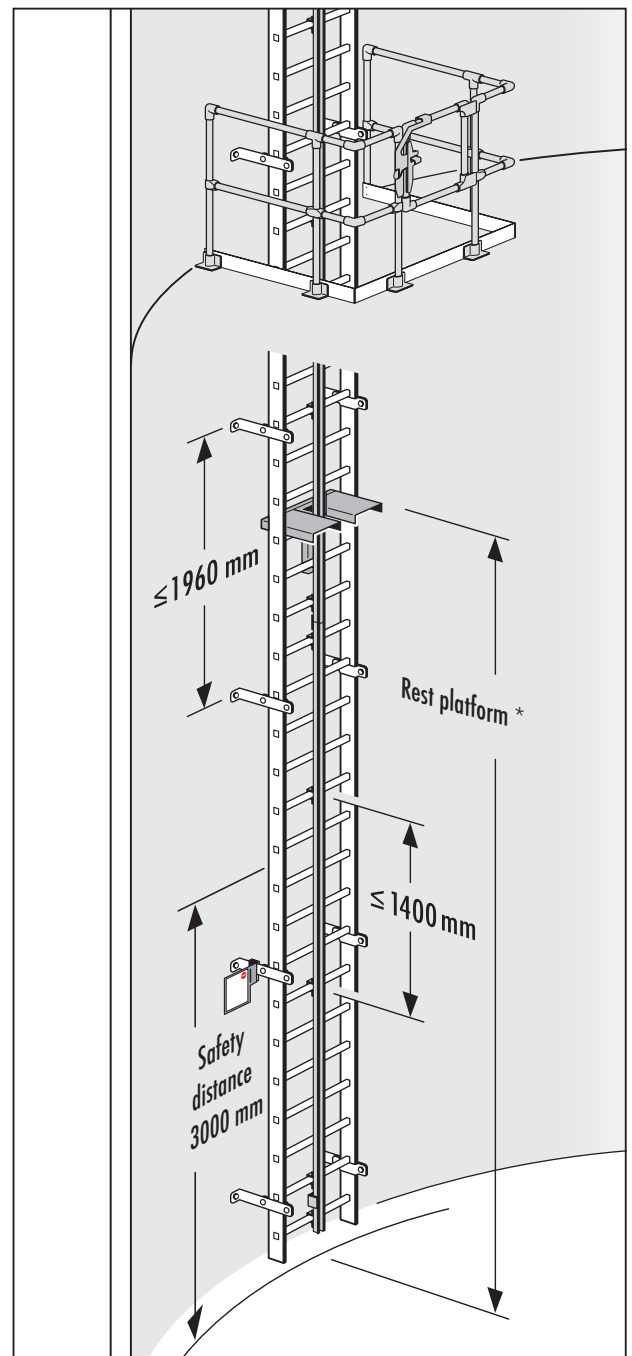

* Distance between rest platforms:

EN ISO 14122-4 = 12 m | DIN 18799-1 = 10 m | EN 50308 = 9 m (Wind turbines)

10.2 Assembly Instructions

When assembling the fall arrest rail and other system components using hammerhead screws, proceed as follows:

1. Insert the hammerhead screw into the opening of the rail profile.
2. The hammerhead screw must be turned in the profile of the fall arrest rail and positioned in the opening of the rail profile using the square neck. Then a secure connection is guaranteed.
3. Check the horizontal position of the slit mark on the hammerhead screw [x] !
4. Tighten both nuts. The nuts are to be tightened on first fitting with a torque of at least 27 Nm.



The fall arrest rail (Mat.: aluminium) is to be fitted to the vertical with a tolerance of max. -3° to $+15^\circ$.



When conducting the annual test for the fall arrest rail, the joints must be checked to ensure they are screwed tight.

Check the horizontal position of the slit mark on the hammerhead screw [x] !

If a nut has worked loose, it must be tightened again with a tightening torque of at least 27 Nm.

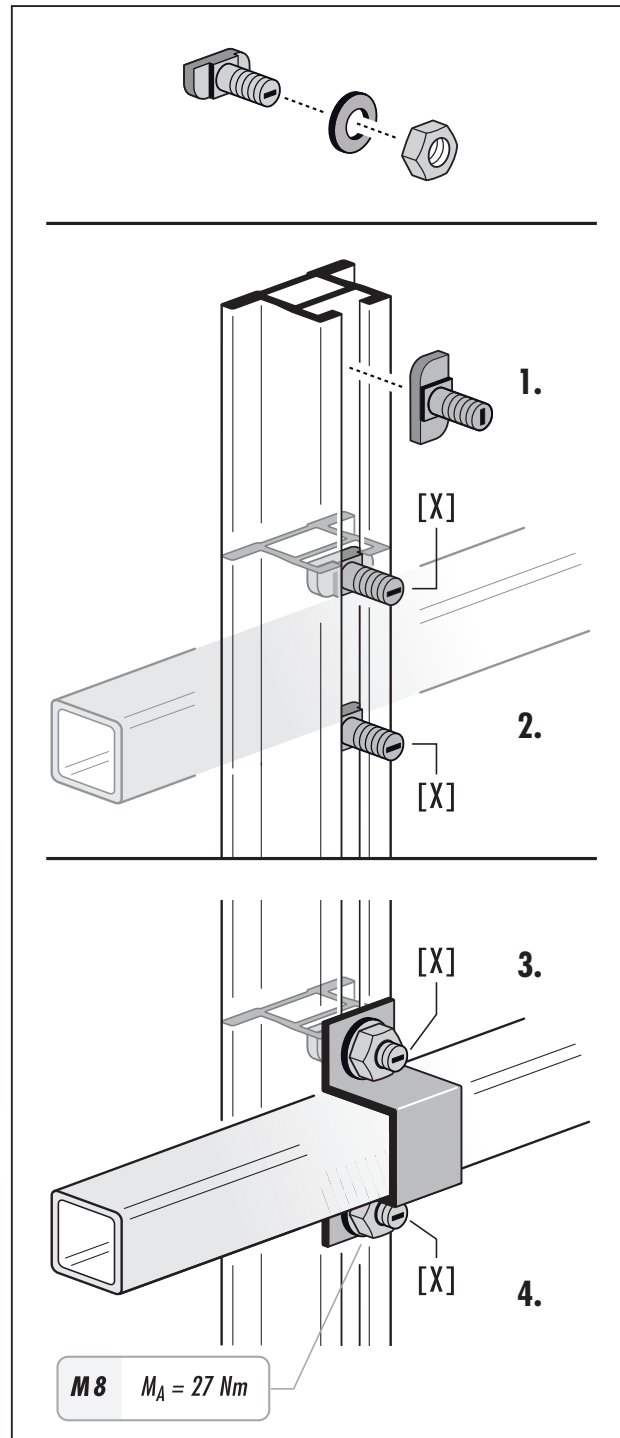

10. Assembly of Fall Arrest Rails

10.3 Securing the rail to the rung (Examples)

In general, a distance of ≤ 1400 mm is permitted when attaching the fall arrest rail to a Hailo vertical ladder.

If assembling the fall arrest rail to ladders of other manufacturers or to ladder systems compliant with EN ISO 14122-4, DIN 18799-1, that are subsequently equipped with the H-50.2 fall arrest system, a maximum fixing distance of 1120 mm is allowed.

All ladders must comply with the relevant standards and regulations (see page 19).

A) Assembly on rungs (aluminium vertical ladder)

The fall arrest rail is attached centrally to a ladder by means of a hammerhead screw and rung clip (see assembly information on page 27).

B) Assembly on rungs (steel / stainless steel ladder)

The fall arrest rail is attached centrally to a ladder by means of a hammerhead screw and rung clip (see assembly information on page 27).

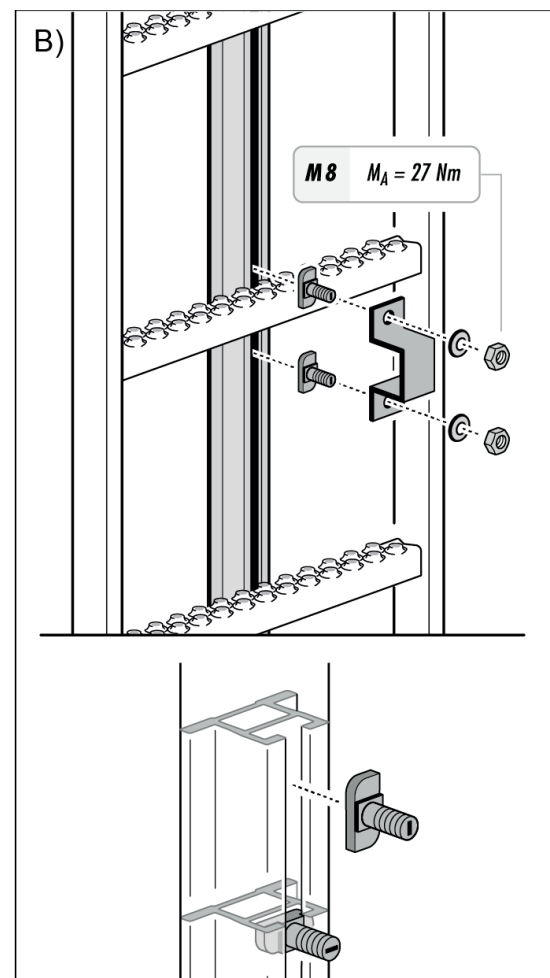
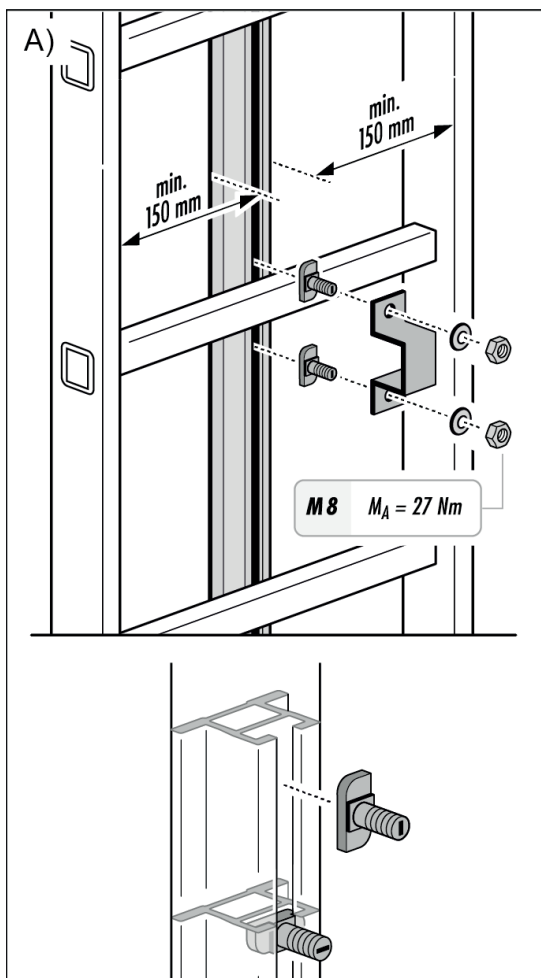

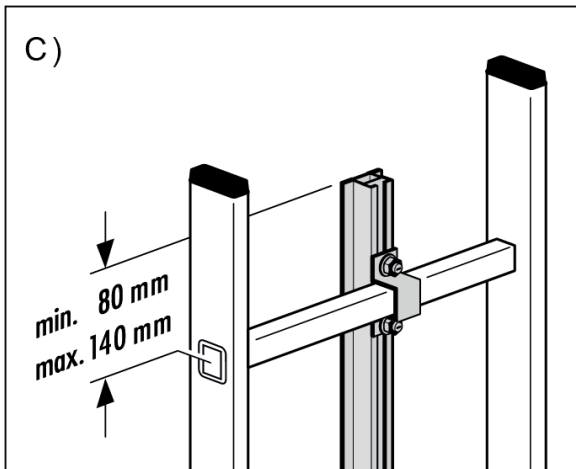

C) Projection of the fall arrest rail beyond the rung

The minimum projection of the H-50.2 fall arrest rail measured from the centre of the rung is 80 mm.

The maximum projection of the H-50.2 fall arrest rail measured from the centre of the rung is 140 mm.

These figures apply for the first rung from the top and bottom after the start and end of the rail respectively.

10.4 Folding rest platform (example of installation)

- According to DIN 18799-1, where the height of a system is ≥ 10 m a folding rest platform is to be installed at a height of max. 10 m above the access level.

A folding rest platform must then be installed on the vertical ladder every 10 m thereafter.

- In wind turbines, a maximum distance of ≤ 9 m is permitted between 2 folding rest platforms in accordance with DIN 50308.
- According to EN 14122-4, a maximum distance of ≤ 12 m is permitted between 2 folding rest platforms.

Assembly a folding rest platform (Example of installation)

Assembly of folding rest platform - for two-piece standing area - on the rung. (Aluminium vertical ladder, inside dimension of ladder = > 370 mm)

Note:

Ensure that when the hexagon nut [X] is tightened the folding rest platform still easily pivots.



The fall arrest rail must be secured to the ladder above and below the 1st rung in each case.

It is essential that the distances between the fastening points are observed, even if these are smaller than the maximum permitted in the specification (see above).

A replacement rail section within a ladder system must be mounted on the ladder at a minimum of two fixing points.

A ladder system must have a minimum of 5 fixing points in any case. This must also be ensured if the ladder system consists of just one fall arrest rail.

Sections of fall arrest rail which have been properly fitted may be regarded as continuous fall arrest rail.

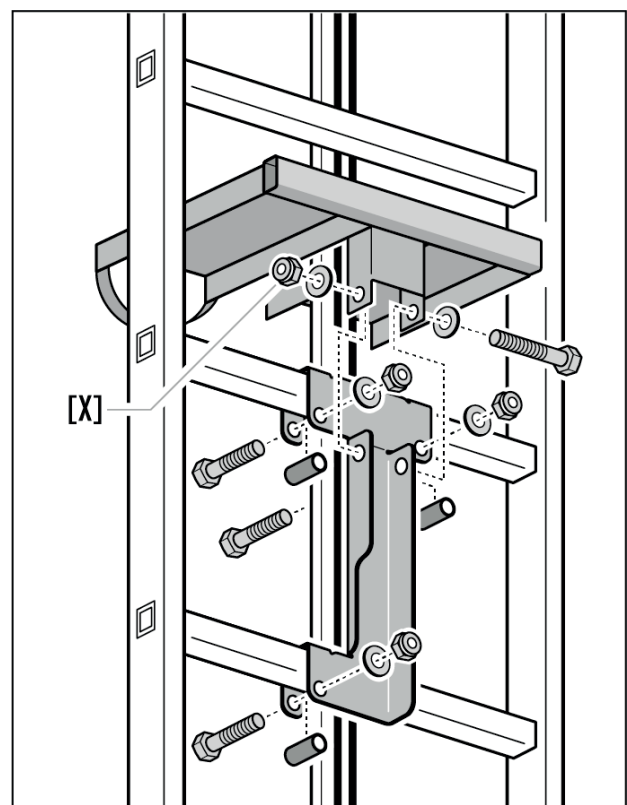

10. Assembly of Fall Arrest Rails

10.5 Assembly of rail connector

A) Assembly of rail connector / Fitting to rail joint

Attaching two fall arrest rails using a rail connector.

The hammerhead screw must be turned in the profile of the fall arrest rail and positioned in the opening of the rail profile using the square neck.

The protruding lug of the rail connector [X] must also be positioned in the opening of the rail profile. Then a secure connection is guaranteed. (see assembly information on page 27).

Distance between the fall arrest rails (rail joint) = 0 mm to max. 4 mm.

To compensate for the difference in length due to variations in temperature, a gap of up to 4 mm may be left at the rail joint.



At each rail joint, the fall arrest rails must be attached to each other by means of a rail connector.

At each rail joint the fall arrest rails must be attached to the ladder rungs using a rung clip [Y] at the end of the lower and the start of the upper fall arrest rail.

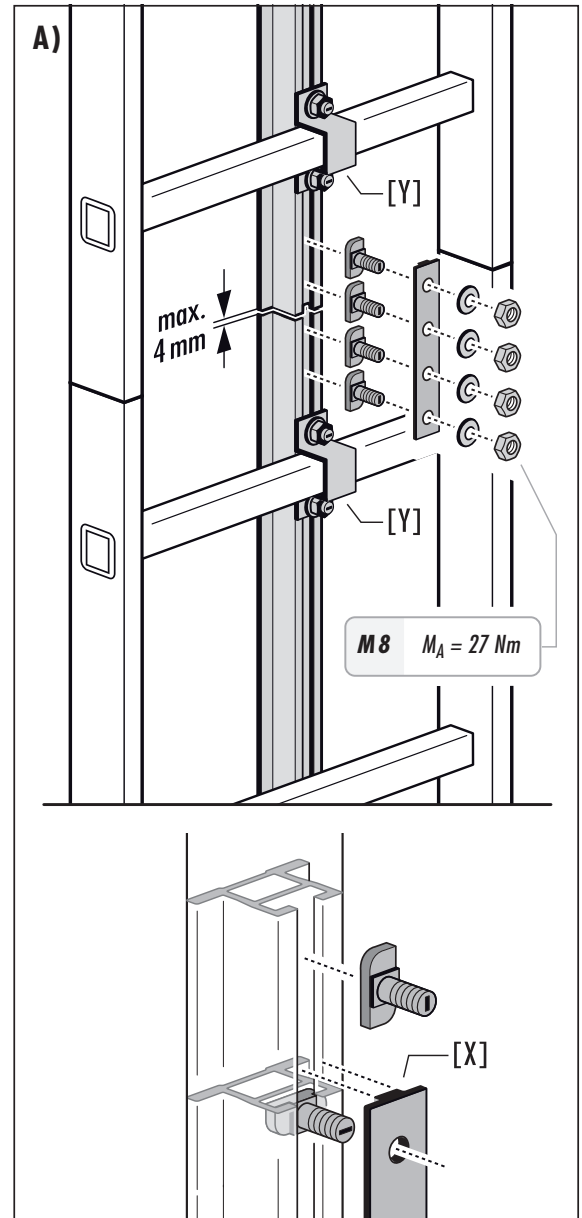

10.6 Assembly of variable rail connector

Prerequisites:

- A rung connector must be fitted to the rung above and below.
- At least 5 rung clamps must be fitted below the variable rail connector.
- The variable rail connector must not be mounted on the first part of the fall arrest rail from below.
- The ladder section on which a variable rail connector is used must be fastened with at least one ladder bracket (e.g. no flange transition piece).
- Gap when mounting the variable rail connector max. 0-1 mm.

Assembly of the variable rail connector

Use recommended for long ladder routes (> 100 m) or strongly swaying towers. Mount approximately halfway along the climbing path.

- Insert the variable rail connector into the fall arrester rail from above.
- Place the counter plate so that it is flush with the lower arrester rail and screw both parts together.
- The gap between the two arrester rails must be kept as small as possible during installation (0-1 mm) so that gap compensation is possible for variations in the arrester rail up to a maximum of 4 mm.

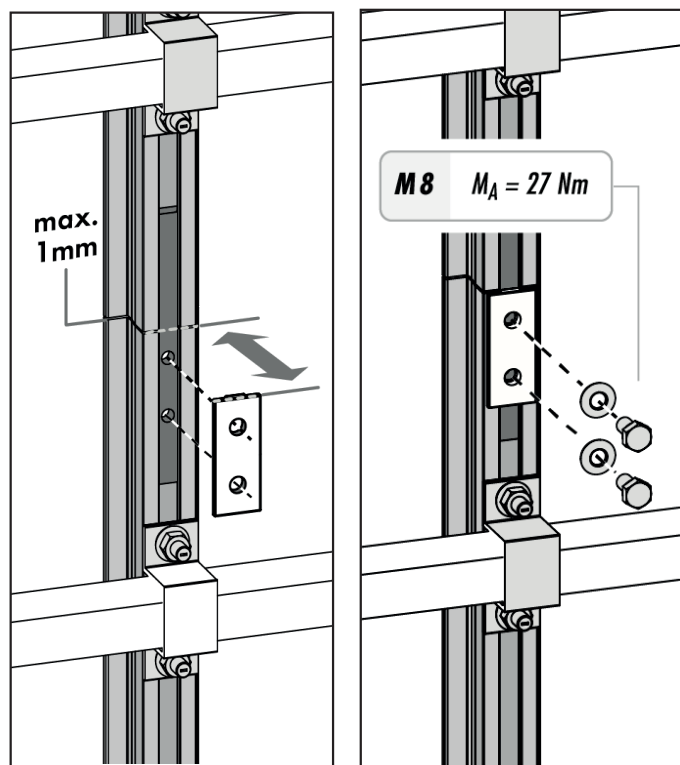

10.7 Assembly compensational rail connector

The compensational connector, available in lengths of 4, 8 and 12 mm, can be used instead of a normal rail connector if the gap between the arrester rails is too large.

- Turn the hammerhead screw in the fall arrester rail profile and position it with the square attachment in the opening of the rail profile. Insert the rail connector with the protruding guide into the same opening.
- **Place the rail connector so that the compensational connector rests on the lower arrester rail. There must then be a maximum gap of 4 mm above the compensational connector to the top fall arrester rail.**

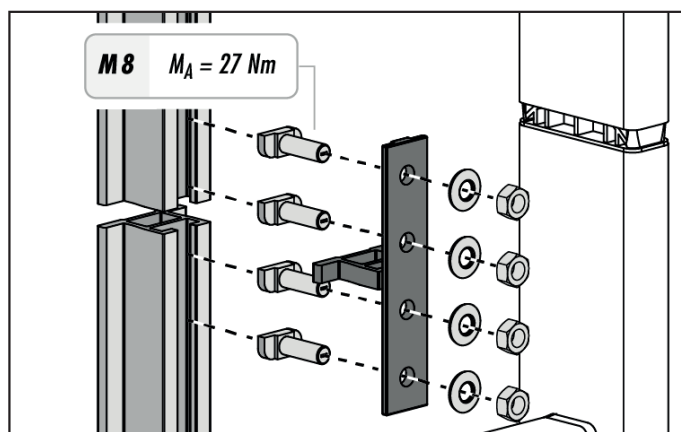
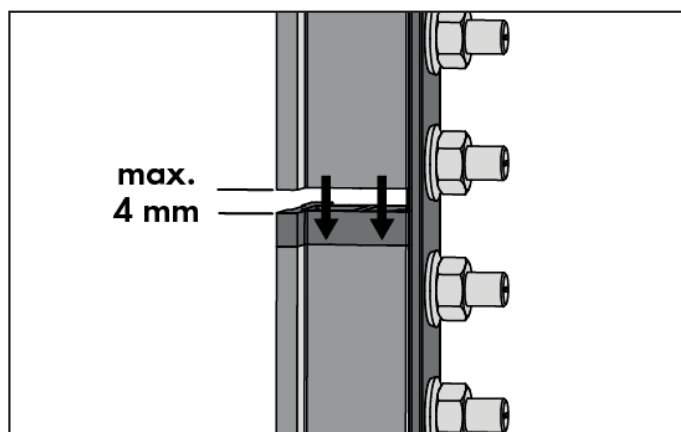

10. Assembly of Fall Arrest Rails

10.8 Assembly of end-stop and locking for third party device

A) Assembly of end-stop

An end-stop is always fitted at the start resp. the end of a fall arrest rail. The end-stop is fitted directly onto the fall arrest rail above and below.

The hammerhead screw must be turned in the profile of the fall arrest rail and positioned in the opening of the rail profile using the square neck. Then a secure connection is guaranteed (see assembly information on page 27).

B) Positioning of the end-stop

The end-stop [X] is positioned in such a way that it is located - both above and below - between the first two rungs of the vertical ladder after the start of the rail.

Alternatively, the end stop [X] can be positioned in such a way that it is attached before the first rung after the start of the rail and below the last rung of the ladder at the bottom.

C) Assembly of locking for third-party device

A locking for third-party devices is an optional part. If needed it is fitted at the beginning of a fall arrest rail. An height of 1,5m from the beginning of the rail for the assembly of the locking is recommended. The label may be mounted at a maximum height of 3 m from access level (ground).

The hammerhead screw must be turned in the profile of the fall arrest rail and positioned in the opening of the rail profile using the square neck. Then a secure connection is guaranteed (see assembly information on page 27).



At the start and at the end of a ladder system as well as at each withdrawal point or break in the fall arrest rail, an end-stop must be fitted to stop the fall arrester from accidentally slipping out.



Information for fitting an H-50.2 fall arrest system to a wind turbine:

A safety stop must be fitted to the top end of the rail in each section to prevent users from becoming accidentally disconnected from the fall arrest system.

This safety stop is removed when the fitting work is completed.

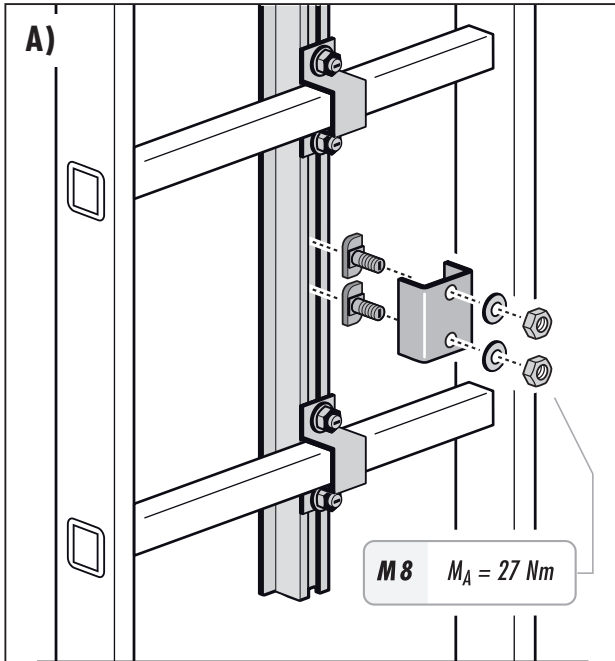

1.

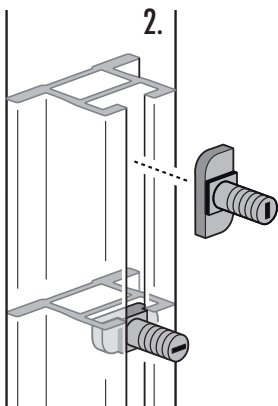

2.

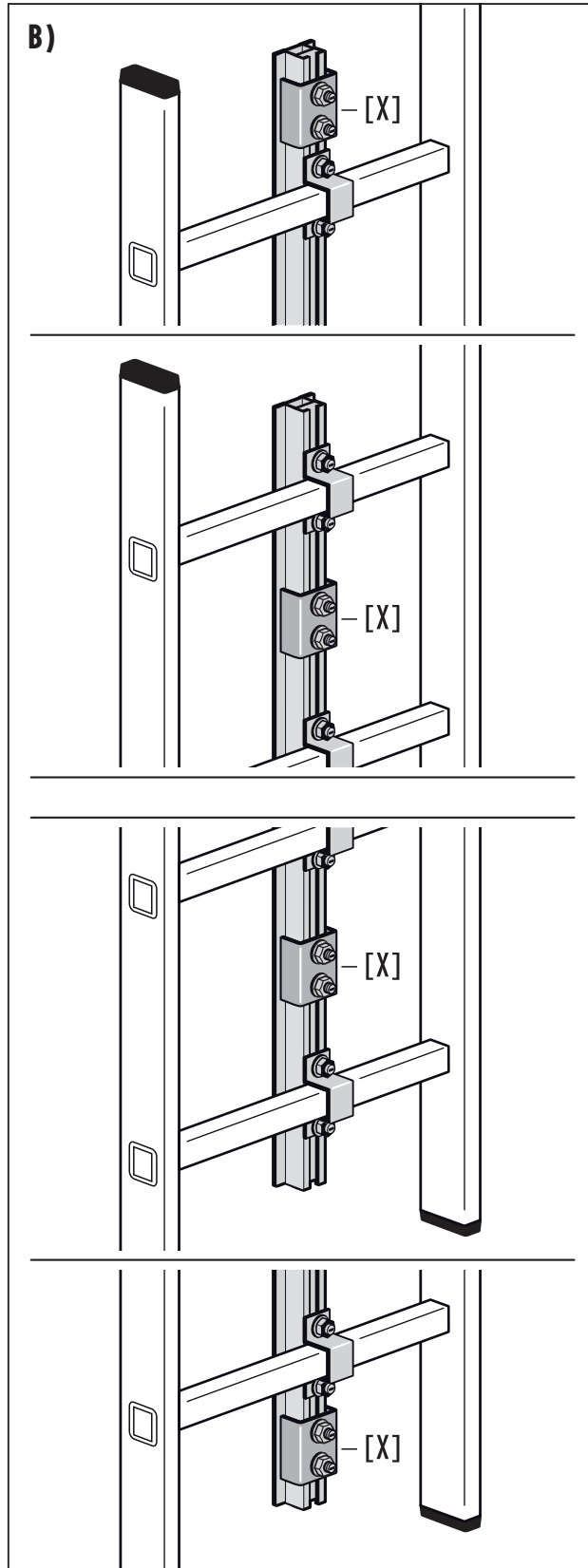
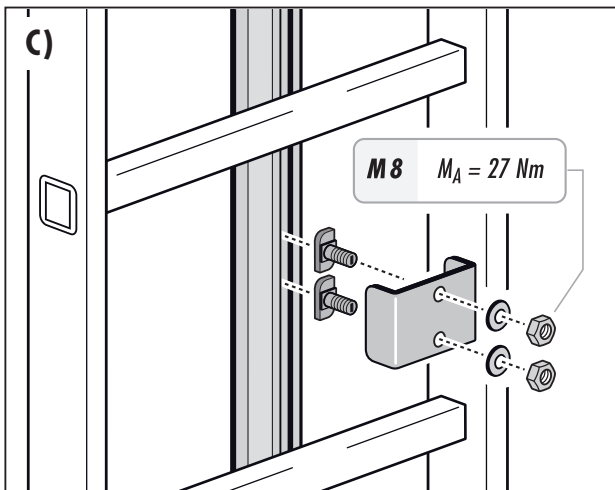
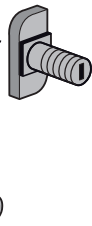

10. Assembly of Fall Arrest Rails

10.9 Assembly and handling of the insertable entrance aid

Note regarding the insertable entrance aid:

- The H-50.2 entrance aid is designed solely for use in the H-50.2 fall arrest system and may only be used in conjunction with a H-50.2 fall arrest rail.
- If only one H-50.2 insertable entrance aid [Z] is to be used on multiple H-50.2 fall arrest systems, the coupling unit [X] must be mounted on each ladder.

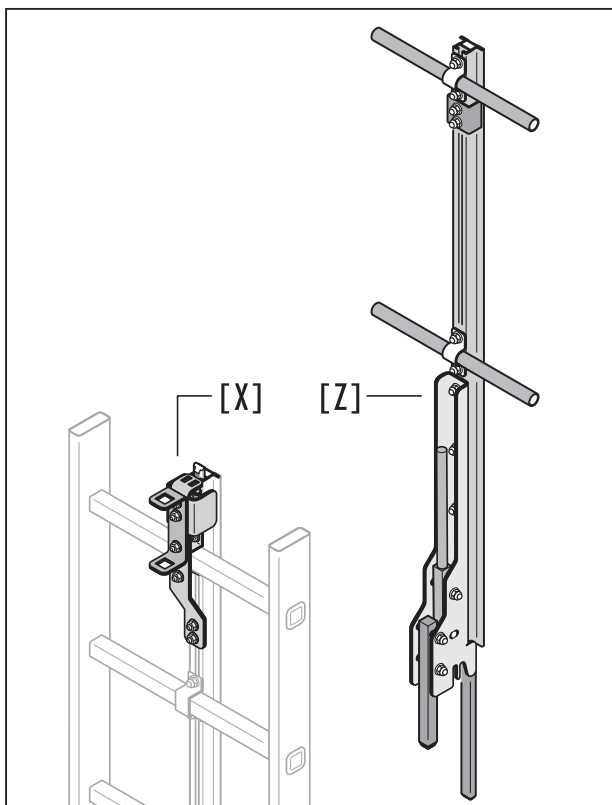

A) Mounting the coupling unit [Y] on the fall arrest rail:

1. The fall arrest rail must project 125 mm beyond the topmost rung of the ladder.

Insert the connector [X-1] into the fall arrest rail [Y] and fix it in position using 4 set screws.

Secure the fall arrest rail to the top rung using a rung clip. Then screw on the distance bolt [X-8] by hand.

2. Fit the end-stop [X-2], compression springs [X-3] and reinforcement [X-4].

Mount the cover [X-5] and fix it in position with 2 hammer-head screws [X-6].

Attention! The upper edge of the cover [X-5] must be flush with the upper edge of the fall arrest rail [Y].

Screw the complete coupling unit with the cover [X-5] and the bracket [X-7] to the fall arrest rail respectively the ladder rung.

B) Fitting the insertable entrance aid:

1. Fit the entrance aid into the bracket [X-7] and the profile of the fall arrest rail [Y] as illustrated.

2. Pull the lever [Z-1] so that both locking hooks [Z-2] can be introduced into the opening of the cover [X-5].

The lever [Z-1] engages automatically on being released, fixing the entrance aid in position.

Check that the entrance aid is located safely and securely before using it.

C) Removing the insertable entrance aid:

Actuate the lever [Z-1] to release the locking provided by the two locking hooks [Z-2] and pull the entrance aid up.

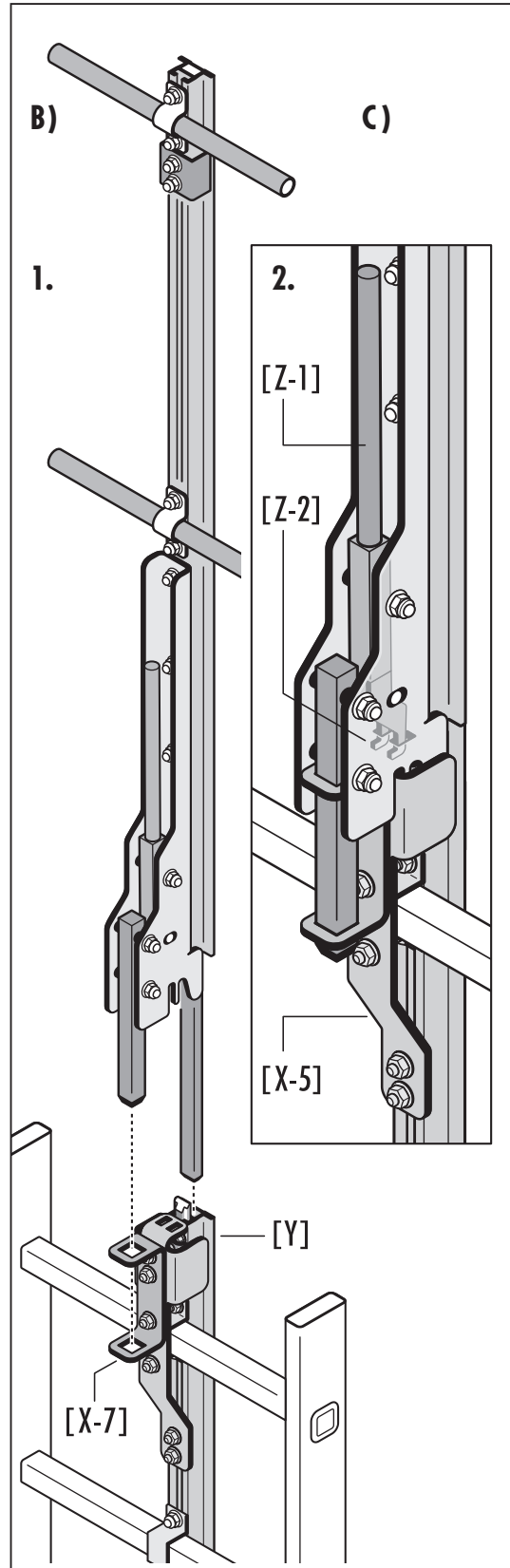
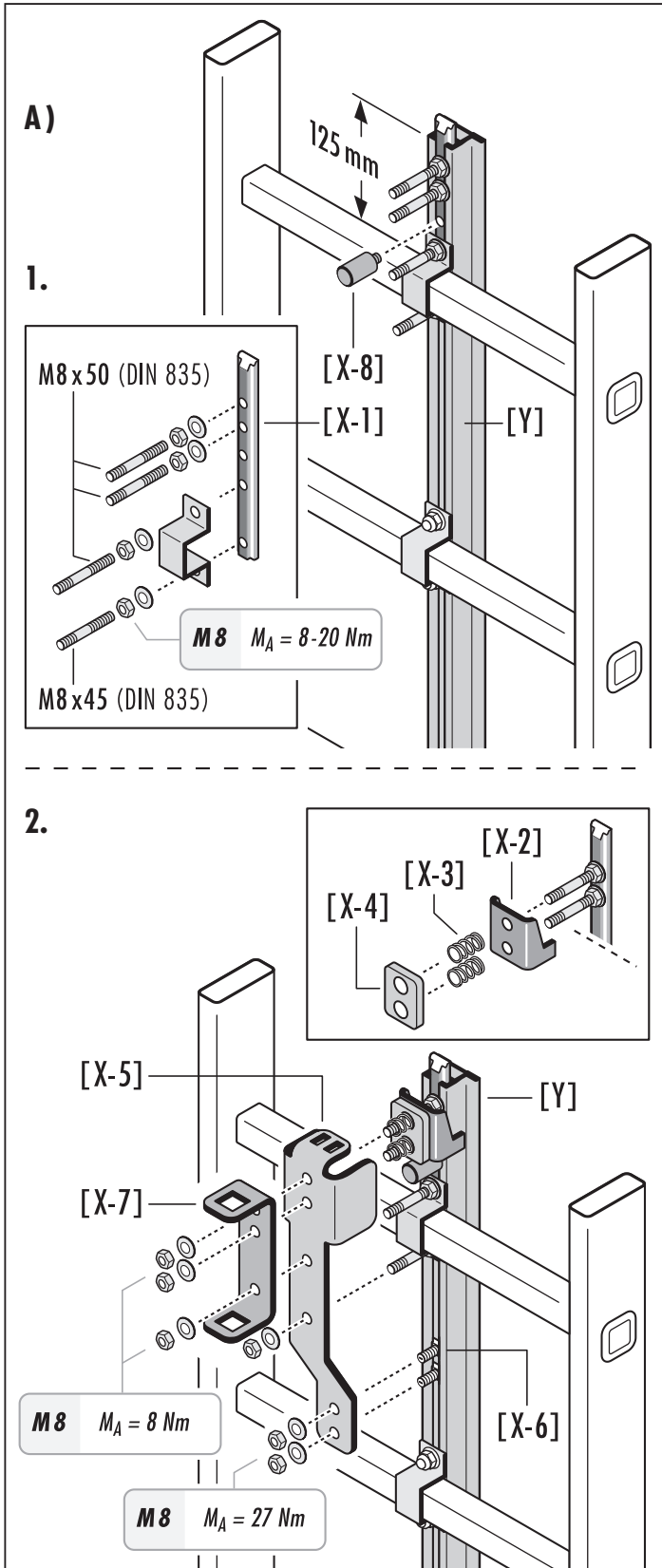

11. Use of H-50.2 Fall Arrest System

Entry and exit points of the fall arrest system

- On tall buildings or as means of access to machinery, fall arrest systems are a mandatory requirement above a fall height
≥ 5 m (per DIN 18799-1) or
≥ 3 m (per EN ISO 14122-4).
- Entry and exit points are situated at the start and end of the climb, and at rest platforms along the fall arrest system.
- Entry into the fall arrest system and exit from the fall arrest system is gained using the Hailo PARTNER H-50.2 fall arrester directly on the fall arrest rail.
- There is an end-stop at the entry and exit points at the bottom and top of the ladder.
- This end stop prevents the fall arrester from slipping out of the fall arrest rail inadvertently.



Both on entering and leaving the fall arrest system, the user must be secured to an approved fastening point appropriate to local conditions to prevent falling.

This requires the karabiner clip [A] of the means of attachment – in accordance with EN 363 – to be attached either to an approved fastening point [B] – in accordance with EN 795 – on the building or to another structure.

- The existence and position of approved fastening-points must be clarified with the plant operator.
- Stop points and stop devices used in a climbing system are to be positioned so that free falling and the fall height are restricted to a minimum. The fastening point must be within the radius of action for the user while still secured on the fall arrest device.
- In general, the user should always select stop devices / stop points that are situated above them.
A check should be made for possible stop points and stop devices before each use.



Any places on the fall arrest system where the Hailo PARTNER H-50.2 fall arrester might inadvertently slip out must be secured with an end-stop.

All entry and exit points must always be accessible from a safe position. The user may need to protect against falls either collectively or through a safety system.

At no time should there be any risk of falling.

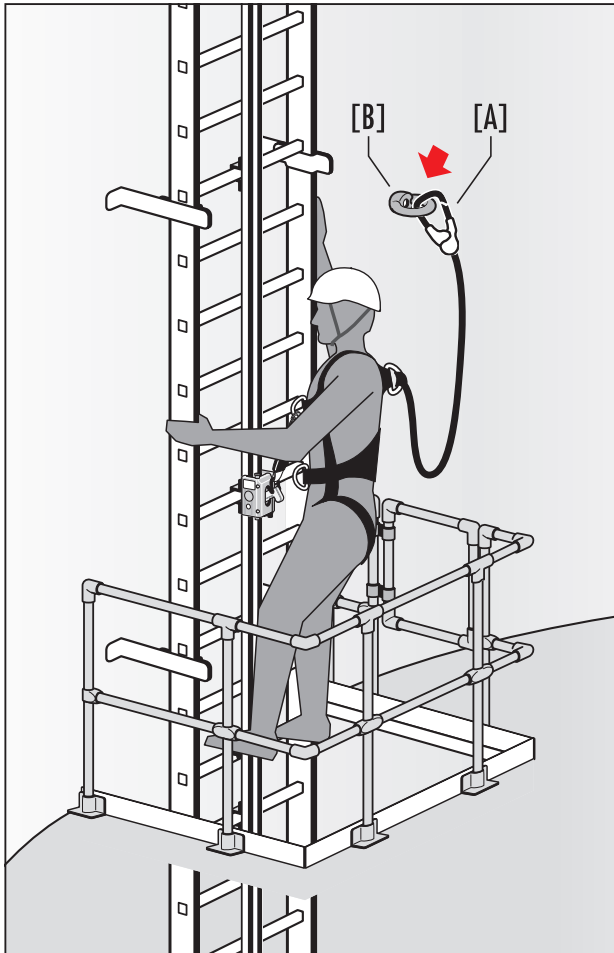

Cleaning and Care

- Where component parts of the fall arrest system – in particular the fall arrest rail – become contaminated by concrete dust, sand, soil or other substances, this should be cleaned off with warm water (max. 40 °C) and an acid-free cleaner.

Testing and maintenance:

- Fall arrest systems must be inspected and documented for good working order and functionality at least once a year by trained/authorised personnel.

An expert/authorised person is:

A person who on the basis of specialist training (cf. DGUV 312-906/TRBS 1203) and his personal experience, has gained the necessary knowledge for this safety device, and who is also familiar with the generally recognised state-of-the-art and the relevant guidelines and regulations to the extent that he can assess its safe condition for use and its appropriate application.

See test schedule and documentation on the H-50.2 fall arrest system on pages 46-53.

- The testing of all components, each individual subsystem and system must be documented.

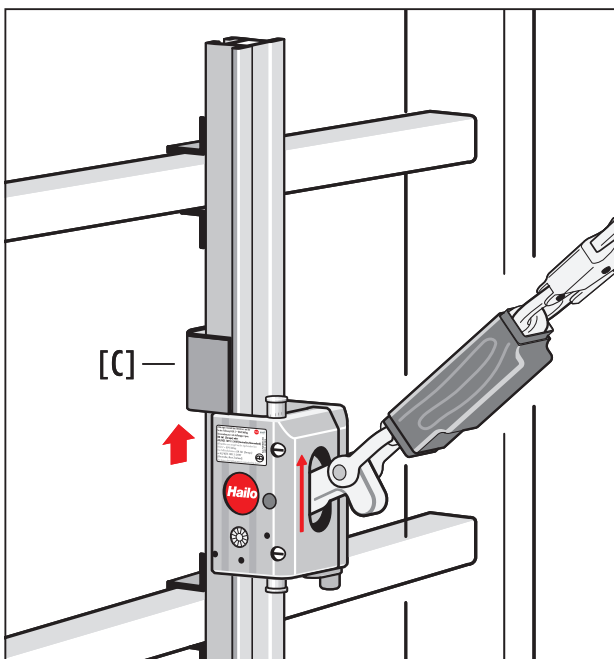

12. Markings and Notices

Please pay special attention to all markings, stickers with safety information and safety regulations.

- A) Information on H-50.2 fall arrest system: Safety instructions for attaching the fall arrester and using the H-50.2 fall arrest system.
- B) Type plate for the vertical ladder: Information on the material and dimensions of the ladder as well as the load capacity.
- C) Plate with ladder markings: Information on the fall arrest system. The H-50.2 vertical ladder must be inspected at least once a year by trained personnel and documented with a test badge.
- D) Type plate for the fall arrest rail.
- E) Batch number for the fall arrest rail.
- F) Label of locking for third-party devices
Maximum installation heights of 3m from access level (ground).



The H-50.2 fall arrest system must be identified with a type plate at the point of access which indicates the type of fall arrester to be used with the H-50.2 fall arrest system.

When new types of fall arrester are used, the operator must ensure that this information is clearly visible to the user.



If necessary, customer-specific safety and information signs can also be used; however, these are not described or illustrated here.

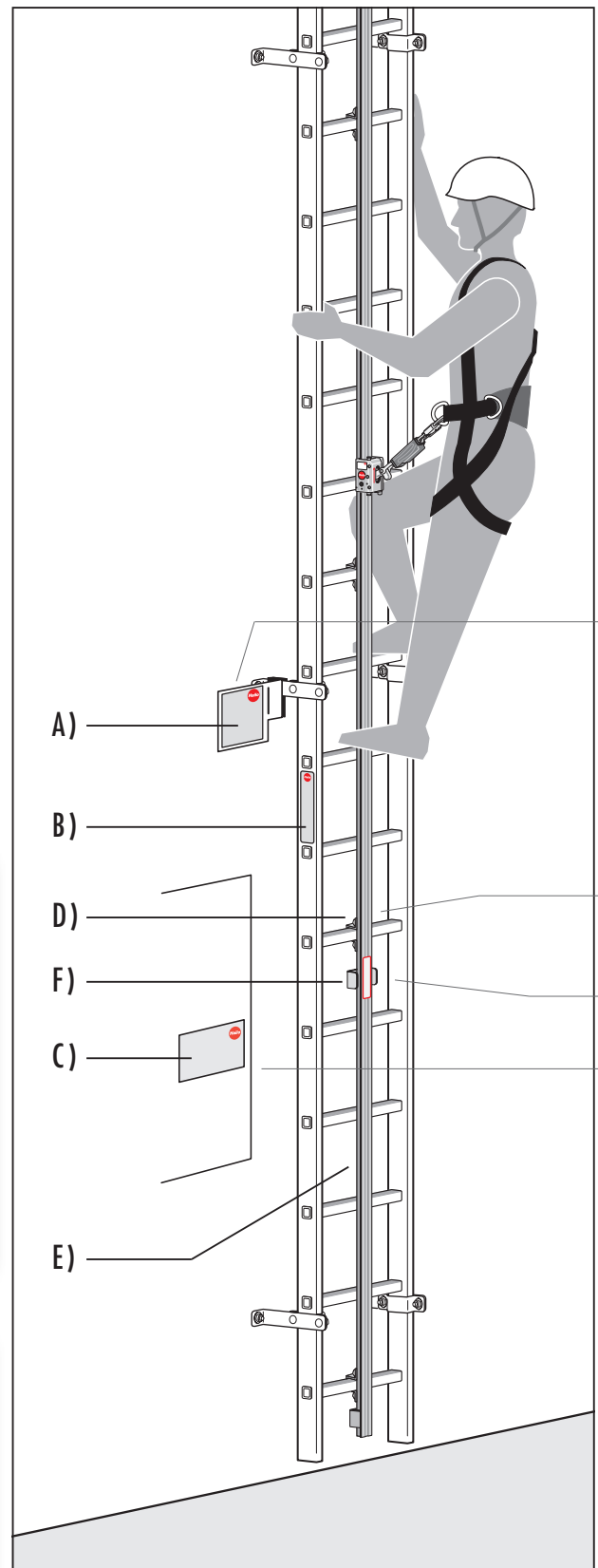

H-50.2 System gemäß DIN EN 353-1:2018, ANSI Z359.16-2016 und AS/NZS 1891.3:1997

Darf ausschließlich mit dem Auffanggerät Hailo PARTNER H-50.2 in Verbindung mit Auffanggurten nach EN 361 (Europa), OSHA/ANSI (Nordamerika) oder AS/NZS 1891.1:2007 (Australien, Neuseeland) genutzt werden.

Achtung!

- Die Schutzwirkung des Auffanggerätes ist ab 3 m Steighöhe über Zugangsebene gegeben! (Sicherheitsabstand = 3 m)
- Zwischen 2 steigenden Personen ist ein Abstand von mindestens 6 m einzuhalten.
- Max. 10 Personen dürfen das System gleichzeitig benutzen.

CE 0158

H-50.2 System according to DIN EN 353-1:2018, ANSI Z359.16-2016 and AS/NZS 1891.3:1997

May only be used with fall arrester Hailo PARTNER H-50.2 in conjunction with EN 361 (Europe), OSHA/ANSI (North America) or AS/NZS 1891.1:2007 (Australia, New Zealand) compliant safety harness.

ATTENTION!

- The safety harness provides protection from a height of 3 m above the access level! (Safety margin = 3 m)
- There should always be a gap of at least 6m between any two people on the fall arrest system.
- No more than 10 persons may use the system at the same time.

H-50.2 Système conforme à DIN EN 353-1:2018, ANSI Z359.16-2016 et AS/NZS 1891.3:1997

Doit être utilisé exclusivement avec l'antichute Hailo PARTNER H-50.2 et avec des harnais de sécurité selon EN 361 (Europe), OSHA/ANSI (Amérique du Nord) ou AS/NZS 1891.1:2007 (Australie, Nouvelle-Zélande).

Attention!

- L'effet protecteur de l'antichute n'est réalisé qu'à partir de 3 m de hauteur au-dessus du niveau d'accès! (distance de sécurité = 3 m)
- Entre deux personnes utilisant l'accès, une distance d'au minimum 6 m doit être respectée.
- 10 personnes au maximum peuvent utiliser en même temps le système.

Informationsbroschüre beachten!

Follow manufacturer's instructions included at time of shipment!

Lire attentivement le manuel d'information!



Zutreffendes bei der Montage eintragen bzw. ankreuzen.

For assembly, enter or tick as applicable.

Pour le montage, entrez ou pointez selon le cas.

Montiert
Assembled
Monté



Nächste Prüfung
Next inspection
Prochaine inspection

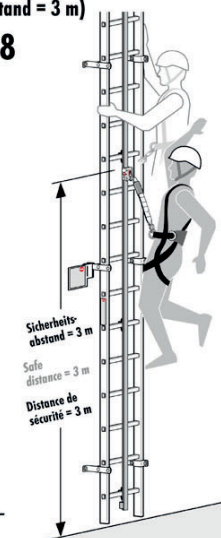

Hailo Wind Systems GmbH & Co. KG
Kaltteiche-Ring 18
35708 Haiger, Germany
www.hailo-windsystems.com
1133759 • 12/2019

CE 0158

Typ: H-50.2 Aluminium
Type: H-50.2 Aluminium



ACHTUNG!

Aufstieg nur mit einem zum Führungsseil oder zur Führungsschiene zugelassenem Auffanggerät. Nur Auffanggurte der Standards EN 361 (Europa), OSHA/ANSI (Nordamerika), AS/NZS 1891.1:2007 (Australien, Neuseeland) oder NBR 15.836 (Brasilien) verwenden!

ATTENTION!

Ascent only using a fall arrester suitable for the guiding cable or guide rail. Use only safety harnesses acc. to EN 361 (Europe), OSHA/ANSI (North America), AS/NZS 1891.1:2007 (Australia, New Zealand) or NBR 15.836 (Brazil).

ATTENTION!

Ne montez sur l'échelle que si elle est munie d'un système antichute adapté au câble ou au rail de guidage. Utilisez exclusivement des harnais de sécurité aux normes EN 361 (Europe), OSHA/ANSI (Amérique du Nord), AS/NZS 1891.1:2007 (Australie, Nouvelle-Zélande) ou NBR 15.836 (Brésil).

Leiter entspricht:

Ladder complies to:

L'échelle satisfait aux normes:

OSHA 1926.1053

OSHA 1910.23

ANSI 14.3 (Parts)

EN ISO 14122-4: 2016

AS 1657 (nur/only/seul 72x25 & 60x20)

Zugang nur für im Steigschutz unterwiesene Personen.

Access only permitted for persons trained in fall protection.

Accès réservé aux personnes au courant du système antichute.

Montiert
Assembled
Monté



Nächste Prüfung
Next inspection
Prochaine inspection



Zulässige Belastung
Gewicht = 150 kg

Permitted load
Weight = 150 kg

Charge max. autorisé
Poids = 150 kg

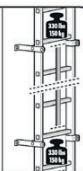

DIN EN 353-1:2018
AS/NZS 1891.3:1997
ABNT NBR 14.627/2010
ANSI Z359.16-2016

1025179 - 12/2019

H-50.2 System Hailo WIND SYSTEMS

Zugelassenes Auffanggerät:
Approved fall arrester:

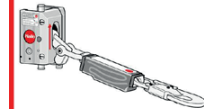

Hailo PARTNER H-50.2

Auffanggeräte des H-50 Systems sowie Auffanggeräte anderer Hersteller sind nicht zulässig!

Fall arresters of the H-50 system and fall arresters from other manufacturers are not permitted!

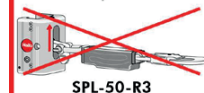

SPL-50-R3



Hailo PARTNER R1

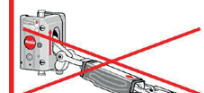

SPL-50-PRO

1122999 • 06/2021

13. Rescue Measures



The contractor or operator of a plant needs to draw up a plan that takes account of all potential emergencies that might arise when using the fall arrest system.

Please refer to the following publications which cover the mandatory regulations (Germany):

Regulations of the Employer's Liability Insurance Association

- BGR/GUV-R 198
Use of personal protective equipment to prevent falls from height
- BGR/GUV-R 199
Use of personal protective equipment for rescue at height and underground

Important information on the use of personal protective equipment:

- It is essential that personal protective equipment is used to protect against falls when working in locations that are difficult to reach due to their height and position.
- Personal protective equipment for rescue at height and underground is an integral part of rescue systems with which individuals can be raised, lowered or extricated from an emergency situation.
This includes: rescue harnesses, suspension loops, lifting equipment, abseil equipment, means of attachment, attachment components and stop devices.
- Before selecting and using personal protective equipment for rescue, operators have to carry out a risk assessment in accordance with § 4 and 5 of the Health and Safety at Work Act.
- According to § 2 of the Use of PPE ruling, the operator must carry out an assessment of the equipment which is available for rescue purposes.
Only personal protective equipment (PPE) with the CE mark is permitted to be selected for use in rescue measures.
- Only approved rescue harnesses are permitted for use.
Harnesses that comply with EN 361 (for Europe), AS/NZS 1891.1:2007 (for Australia/New Zealand) and OSHA/ANSI (North America) can also be used for rescue purposes. Rescue harnesses have at least one fastening point for attaching a means of attachment or karabiner clip.
These fastening points may be rescue eyes at shoulder level, arrester eyes on the reverse or fall arrest eyes. Equipment with retaining eyes to the sides of the harness is not approved for rescue purposes.

Information on First Aid

In the event of a fall and when the individual is left hanging in the fall arrester motionless for a prolonged time (> 15 minutes), this may constitute a serious health risk. There is a risk of suspension trauma/harness hang syndrome (orthostatic shock).

Even if there appear to be no external signs of injury, the individual must sit with raised knees (see Fig. A). It may prove fatal for them if they suddenly lie flat due to overloading of the heart and kidney failure.



It is essential in each case that the patient is examined by a doctor and given medical care to assess the condition of their health.

Contact the doctor on the EMERGENCY number.

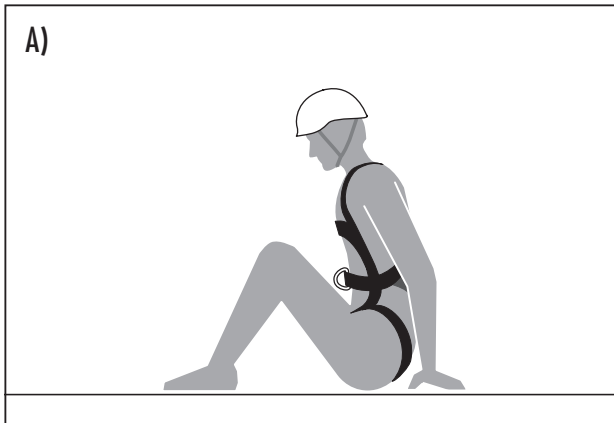

14. Assembly Log H-50.2 Fall Arrest System

Assembly firm (Address):

.....

- The Assembly Manager is responsible for ensuring that the climbing unit and H-50.2 fall arrest system are properly assembled.
- The following checklist is to be completed by the assembly manager in detail and in full, permanently and legibly.
- This test checklist is an integral part of the assembly process and is to be made accessible to the manufacturer or a testing body on request.

Assembly manager:

.....

Points for inspection after the assembly Result:



Fall arrest device	Yes	No
1. Load capacity of the substructure (e.g. ladder) in accordance with requirements	<input type="checkbox"/>	<input type="checkbox"/>
2. Fall arrest rail attached centrally to the ladder	<input type="checkbox"/>	<input type="checkbox"/>
3. Projection of the fall arrest rail at the top / bottom rung min. 80 mm / max. 140 mm	<input type="checkbox"/>	<input type="checkbox"/>
4. Distance where Hailo H-50.2 fall arrest rail is fastened to a Hailo vertical ladder: ≤ 1400 mm (= 5 rungs' distance)	<input type="checkbox"/>	<input type="checkbox"/>
5. Distance where Hailo fall arrest rail is fastened to an existing vertical ladder (not a Hailo vertical ladder): ≤ 1120 mm (= 4 rungs' distance)	<input type="checkbox"/>	<input type="checkbox"/>
6. Assembly of rail connector according to specification Permitted gap between both fall arrest rails in accordance with requirements	<input type="checkbox"/>	<input type="checkbox"/>
7. Assembly of end-stop at each entry and exit point according to specification	<input type="checkbox"/>	<input type="checkbox"/>
8. Rail fastening point at the start and end of a ladder section	<input type="checkbox"/>	<input type="checkbox"/>

Fall arrest device	Yes	No
9. Rail attached before and after every rail joint	<input type="checkbox"/>	<input type="checkbox"/>
10. Coupling for entrance aid (if any) in accordance with requirements	<input type="checkbox"/>	<input type="checkbox"/>
11. Assembly of locking for third-party devices (if any) in accordance with requirements	<input type="checkbox"/>	<input type="checkbox"/>
12. All screw fixings checked. Positioning and tightening torque in accordance with requirements	<input type="checkbox"/>	<input type="checkbox"/>
13. Equipotential bonding for conductive parts	<input type="checkbox"/>	<input type="checkbox"/>
14. Check the variable rail connector (if present): gap dimension max. 1 mm	<input type="checkbox"/>	<input type="checkbox"/>
15. Check the compensational connector (if present): gap dimension max. 4 mm	<input type="checkbox"/>	<input type="checkbox"/>
16. Test run with Hailo Partner H-50.2 fall arrester conducted without problems	<input type="checkbox"/>	<input type="checkbox"/>
Markings: (see chapter on markings and notices)		
17. Plate with ladder markings	<input type="checkbox"/>	<input type="checkbox"/>
18. Description of H-50.2 fall arrest rail	<input type="checkbox"/>	<input type="checkbox"/>
19. Sticker H-50.2 fall arrest system	<input type="checkbox"/>	<input type="checkbox"/>
20. Sticker of approved fall arrester (if any)	<input type="checkbox"/>	<input type="checkbox"/>
21. Test badge	<input type="checkbox"/>	<input type="checkbox"/>

Comments: _____

Place, date

Signature of assembly manager

15. Inspection H-50 Fall Arrest System



Testing must adhere to the respective national operating and testing regulations.

- Fall arrest systems must be inspected for good working order and functionality at least once a year by trained/authorised personnel.

An expert /authorised person is:

A person who on the basis of specialist training (cf. DGUV 312-906 / TRBS 1203) and his personal experience, has gained the necessary knowledge for this safety device, and who is also familiar with the generally recognised state-of-the-art and the relevant guidelines and regulations to the extent that he can assess its safe condition for use and its appropriate application.

See test schedule and documentation for the H-50.2 fall arrest system on pages 46-53.

- In addition, regular checks must be made depending on the respectively applicable environmental conditions. This can mean that the intervals between testing are correspondingly shortened.
 - In the event of a fall, then the H-50.2 fall arrest system must be checked without delay by an expert/an authorised person.
 - Inspection and maintenance of the fall arrest system must always be carried out respecting the instructions in full.
 - The plant operator is responsible for ensuring that testing and maintenance intervals are observed.
- The testing of all components, each individual subsystem and system must be documented.

- The accident prevention regulations must be respected.
BGI 778 - BGR/GUV-R 198 - GUV 6.4 - GUV 16.11
- Test intervals are in accordance with BGR/GUV-R 198.
Additional test intervals may be required due to local/operational conditions (these are to be laid down by the contractor/operator).
- Exception:
Fall arrest devices on chimneys must be inspected at least once a year by an authorised person in accordance with BGI 691.
Testing intervals depend in particular on the frequency of use, the stress imposed during use and the frequency and severity of any defects that have been identified in previous tests.
- Proof of regular testing is required for warranty claims.



Regular checks of the equipment are a mandatory requirement.
The safety of the user is dependent on the effectiveness and the durability of the equipment.

16. Inspection Plan H-50.2 Fall Arrest System

Test schedule for regular testing of the H-50.2 fall arrest system

Annual tests are to be documented in the table on pages 50-53 by trained/authorised personnel:

In the event of a claim, this documentation must be available in full as evidence. The manufacturer must be granted access to this at all times.

Result:



Fall arrest system:

1. Fall arrest ail fastenings	Technical condition, positioning centered on the ladder, preload force, tightly secured (see Page 27)
2. Surface of fall arrest rail	Technical condition
3. Fixing of the fall arrest rail Distance/projection	Fixing distance (Hailo ladder) = ≤ 1400 mm Fixing distance (existing ladder) = ≤ 1120 mm Project at top / bottom rung = min. 80 mm, max. 140 mm Rail fixed at the start and end of a ladder section
4. Rail connectors (incl. variable rail connector / compensational connector, if present)	Technical condition, preload force, tightening torque
5. Rail joints (transitions)	Distance between rails: max. 4 mm Rail fastening before and after each rail joint
6. End-stops	Fastening (securely located) and safety function Assembly at each entry and exit point
7. Locking for third-party devices (if any)	Fastening (securely located) and safety function
8. Entrance aid (if any)	Technical condition (corrosion), tightening torque, securely located Function of end-stop on coupling Lever function (engaging and releasing function)
9. Screw fixings	Technical condition, tightening torque
10. Original markings	All markings present and easily legible?
11. Function test	Used with Hailo PARTNER H-50.2 fall arrester
12. Documentation	Has test been documented correctly and in full?

Inspection 1		Inspection 2		Inspection 3		Inspection 4		Inspection 5	
/		/		/		/		/	
<i>Date (Month/Year)</i>		<i>Date (Month/Year)</i>		<i>Date (Month/Year)</i>		<i>Date (Month/Year)</i>		<i>Date (Month/Year)</i>	
OK	not OK	OK	not OK	OK	not OK	OK	not OK	OK	not OK
<input type="checkbox"/>	<input type="checkbox"/>	<input type="checkbox"/>	<input type="checkbox"/>	<input type="checkbox"/>	<input type="checkbox"/>	<input type="checkbox"/>	<input type="checkbox"/>	<input type="checkbox"/>	<input type="checkbox"/>
<input type="checkbox"/>	<input type="checkbox"/>	<input type="checkbox"/>	<input type="checkbox"/>	<input type="checkbox"/>	<input type="checkbox"/>	<input type="checkbox"/>	<input type="checkbox"/>	<input type="checkbox"/>	<input type="checkbox"/>
<input type="checkbox"/>	<input type="checkbox"/>	<input type="checkbox"/>	<input type="checkbox"/>	<input type="checkbox"/>	<input type="checkbox"/>	<input type="checkbox"/>	<input type="checkbox"/>	<input type="checkbox"/>	<input type="checkbox"/>
<input type="checkbox"/>	<input type="checkbox"/>	<input type="checkbox"/>	<input type="checkbox"/>	<input type="checkbox"/>	<input type="checkbox"/>	<input type="checkbox"/>	<input type="checkbox"/>	<input type="checkbox"/>	<input type="checkbox"/>
<input type="checkbox"/>	<input type="checkbox"/>	<input type="checkbox"/>	<input type="checkbox"/>	<input type="checkbox"/>	<input type="checkbox"/>	<input type="checkbox"/>	<input type="checkbox"/>	<input type="checkbox"/>	<input type="checkbox"/>
<input type="checkbox"/>	<input type="checkbox"/>	<input type="checkbox"/>	<input type="checkbox"/>	<input type="checkbox"/>	<input type="checkbox"/>	<input type="checkbox"/>	<input type="checkbox"/>	<input type="checkbox"/>	<input type="checkbox"/>
<input type="checkbox"/>	<input type="checkbox"/>	<input type="checkbox"/>	<input type="checkbox"/>	<input type="checkbox"/>	<input type="checkbox"/>	<input type="checkbox"/>	<input type="checkbox"/>	<input type="checkbox"/>	<input type="checkbox"/>
<input type="checkbox"/>	<input type="checkbox"/>	<input type="checkbox"/>	<input type="checkbox"/>	<input type="checkbox"/>	<input type="checkbox"/>	<input type="checkbox"/>	<input type="checkbox"/>	<input type="checkbox"/>	<input type="checkbox"/>
<input type="checkbox"/>	<input type="checkbox"/>	<input type="checkbox"/>	<input type="checkbox"/>	<input type="checkbox"/>	<input type="checkbox"/>	<input type="checkbox"/>	<input type="checkbox"/>	<input type="checkbox"/>	<input type="checkbox"/>
<input type="checkbox"/>	<input type="checkbox"/>	<input type="checkbox"/>	<input type="checkbox"/>	<input type="checkbox"/>	<input type="checkbox"/>	<input type="checkbox"/>	<input type="checkbox"/>	<input type="checkbox"/>	<input type="checkbox"/>
<input type="checkbox"/>	<input type="checkbox"/>	<input type="checkbox"/>	<input type="checkbox"/>	<input type="checkbox"/>	<input type="checkbox"/>	<input type="checkbox"/>	<input type="checkbox"/>	<input type="checkbox"/>	<input type="checkbox"/>
<input type="checkbox"/>	<input type="checkbox"/>	<input type="checkbox"/>	<input type="checkbox"/>	<input type="checkbox"/>	<input type="checkbox"/>	<input type="checkbox"/>	<input type="checkbox"/>	<input type="checkbox"/>	<input type="checkbox"/>
<input type="checkbox"/>	<input type="checkbox"/>	<input type="checkbox"/>	<input type="checkbox"/>	<input type="checkbox"/>	<input type="checkbox"/>	<input type="checkbox"/>	<input type="checkbox"/>	<input type="checkbox"/>	<input type="checkbox"/>
YES	NO	YES	NO	YES	NO	YES	NO	YES	NO

16. Inspection Plan H-50.2 Fall Arrest System

Test schedule for regular testing of the H-50.2 fall arrest system

Annual tests are to be documented in the table on pages 50-53 by trained/authorised personnel:

In the event of a claim, this documentation must be available in full as evidence. The manufacturer must be granted access to this at all times.

Result:



Fall arrest system:

1. Fall arrest ail fastenings	Technical condition, positioning centered on the ladder, preload force, tightly secured (see Page 27)
2. Surface of fall arrest rail	Technical condition
3. Fixing of the fall arrest rail Distance/projection	Fixing distance (Hailo ladder) = ≤ 1400 mm Fixing distance (existing ladder) = ≤ 1120 mm Project at top / bottom rung = min. 80 mm, max. 140 mm Rail fixed at the start and end of a ladder section
4. Rail connectors (incl. variable rail connector / compensational connector, if present)	Technical condition, preload force, tightening torque
5. Rail joints (transitions)	Distance between rails: max. 4 mm Rail fastening before and after each rail joint
6. End-stops	Fastening (securely located) and safety function Assembly at each entry and exit point
7. Locking for third-party devices (if any)	Fastening (securely located) and safety function
8. Entrance aid (if any)	Technical condition (corrosion), tightening torque, securely located Function of end-stop on coupling Lever function (engaging and releasing function)
9. Screw fixings	Technical condition, tightening torque
10. Original markings	All markings present and easily legible?
11. Function test	Used with Hailo PARTNER H-50.2 fall arrester
12. Documentation	Has test been documented correctly and in full?

Inspection 6		Inspection 7		Inspection 8		Inspection 9		Inspection 10	
/		/		/		/		/	
<i>Date (Month/Year)</i>		<i>Date (Month/Year)</i>		<i>Date (Month/Year)</i>		<i>Date (Month/Year)</i>		<i>Date (Month/Year)</i>	
OK	not OK	OK	not OK	OK	not OK	OK	not OK	OK	not OK
<input type="checkbox"/>	<input type="checkbox"/>	<input type="checkbox"/>	<input type="checkbox"/>	<input type="checkbox"/>	<input type="checkbox"/>	<input type="checkbox"/>	<input type="checkbox"/>	<input type="checkbox"/>	<input type="checkbox"/>
<input type="checkbox"/>	<input type="checkbox"/>	<input type="checkbox"/>	<input type="checkbox"/>	<input type="checkbox"/>	<input type="checkbox"/>	<input type="checkbox"/>	<input type="checkbox"/>	<input type="checkbox"/>	<input type="checkbox"/>
<input type="checkbox"/>	<input type="checkbox"/>	<input type="checkbox"/>	<input type="checkbox"/>	<input type="checkbox"/>	<input type="checkbox"/>	<input type="checkbox"/>	<input type="checkbox"/>	<input type="checkbox"/>	<input type="checkbox"/>
<input type="checkbox"/>	<input type="checkbox"/>	<input type="checkbox"/>	<input type="checkbox"/>	<input type="checkbox"/>	<input type="checkbox"/>	<input type="checkbox"/>	<input type="checkbox"/>	<input type="checkbox"/>	<input type="checkbox"/>
<input type="checkbox"/>	<input type="checkbox"/>	<input type="checkbox"/>	<input type="checkbox"/>	<input type="checkbox"/>	<input type="checkbox"/>	<input type="checkbox"/>	<input type="checkbox"/>	<input type="checkbox"/>	<input type="checkbox"/>
<input type="checkbox"/>	<input type="checkbox"/>	<input type="checkbox"/>	<input type="checkbox"/>	<input type="checkbox"/>	<input type="checkbox"/>	<input type="checkbox"/>	<input type="checkbox"/>	<input type="checkbox"/>	<input type="checkbox"/>
<input type="checkbox"/>	<input type="checkbox"/>	<input type="checkbox"/>	<input type="checkbox"/>	<input type="checkbox"/>	<input type="checkbox"/>	<input type="checkbox"/>	<input type="checkbox"/>	<input type="checkbox"/>	<input type="checkbox"/>
<input type="checkbox"/>	<input type="checkbox"/>	<input type="checkbox"/>	<input type="checkbox"/>	<input type="checkbox"/>	<input type="checkbox"/>	<input type="checkbox"/>	<input type="checkbox"/>	<input type="checkbox"/>	<input type="checkbox"/>
<input type="checkbox"/>	<input type="checkbox"/>	<input type="checkbox"/>	<input type="checkbox"/>	<input type="checkbox"/>	<input type="checkbox"/>	<input type="checkbox"/>	<input type="checkbox"/>	<input type="checkbox"/>	<input type="checkbox"/>
<input type="checkbox"/>	<input type="checkbox"/>	<input type="checkbox"/>	<input type="checkbox"/>	<input type="checkbox"/>	<input type="checkbox"/>	<input type="checkbox"/>	<input type="checkbox"/>	<input type="checkbox"/>	<input type="checkbox"/>
<input type="checkbox"/>	<input type="checkbox"/>	<input type="checkbox"/>	<input type="checkbox"/>	<input type="checkbox"/>	<input type="checkbox"/>	<input type="checkbox"/>	<input type="checkbox"/>	<input type="checkbox"/>	<input type="checkbox"/>
<input type="checkbox"/>	<input type="checkbox"/>	<input type="checkbox"/>	<input type="checkbox"/>	<input type="checkbox"/>	<input type="checkbox"/>	<input type="checkbox"/>	<input type="checkbox"/>	<input type="checkbox"/>	<input type="checkbox"/>
<input type="checkbox"/>	<input type="checkbox"/>	<input type="checkbox"/>	<input type="checkbox"/>	<input type="checkbox"/>	<input type="checkbox"/>	<input type="checkbox"/>	<input type="checkbox"/>	<input type="checkbox"/>	<input type="checkbox"/>
<input type="checkbox"/>	<input type="checkbox"/>	<input type="checkbox"/>	<input type="checkbox"/>	<input type="checkbox"/>	<input type="checkbox"/>	<input type="checkbox"/>	<input type="checkbox"/>	<input type="checkbox"/>	<input type="checkbox"/>
YES	NO	YES	NO	YES	NO	YES	NO	YES	NO

17. Documentation of the Inspection H-50.2 Fall Arrest System

Documentation for conducting regular inspections and/or repairs

<i>Product description / Trade name</i>	<i>Manufacturer / Supplier</i>
	<p>Hailo Wind Systems GmbH & Co. KG Kalteiche-Ring 18, 35708 Haiger, Germany Tel. +49 (0) 2773 82-1410 info@hailo-windsystems.com www.hailo-windsystems.com</p>
<i>Identification mark</i>	
<i>Batch number / Serial number</i>	

<i>Date</i>	<i>Reason of work: a) Regular check b) Repair</i>	<i>Test outcome of the periodic inspection</i>	



(Copy this double page when additional information needs to be entered)

<i>Date of manufacture / Expiry date</i>	<i>Date of the first use</i>
<i>Date of purchase</i>	<i>Further information</i>

	<i>Repairs carried out</i>	<i>Name and signature of expert</i>	<i>Date of next regular check</i>

17. Documentation of the Inspection H-50.2 Fall Arrest System

Documentation for conducting regular inspections and/or repairs

<i>Product description / Trade name</i>	<i>Manufacturer / Supplier</i>
	<p>Hailo Wind Systems GmbH & Co. KG Kalteiche-Ring 18, 35708 Haiger, Germany Tel. +49 (0) 2773 82-1410 info@hailo-windsystems.com www.hailo-windsystems.com</p>
<i>Identification mark</i>	
<i>Batch number / Serial number</i>	

<i>Date</i>	<i>Reason of work: a) Regular check b) Repair</i>	<i>Test outcome of the periodic inspection</i>	



(Copy this double page when additional information needs to be entered)

<i>Date of manufacture / Expiry date</i>	<i>Date of the first use</i>
<i>Date of purchase</i>	<i>Further information</i>

	<i>Repairs carried out</i>	<i>Name and signature of expert</i>	<i>Date of next regular check</i>

Notes



EMERGENCY TELEPHONE NUMBERS:

We recommend that all users add the emergency telephone numbers listed below as contacts on their mobile phones.

Emergency services:

.....

Fire service:

.....

Plant operator:

.....

Hailo Service Hotline:

.....

Other important phone numbers:

.....

.....

.....

1134319 • Revision 2021-07 • Technische Änderungen vorbehalten